

SPECIFICATION

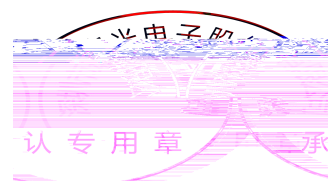

.....	3
General Description	3
.....	3
.....	3
.....	4
.....	5
.....	7
.....	8
.....	11
.....	11
.....	12
.....	13
.....	14
.....	15
.....	15
.....	17
.....	17

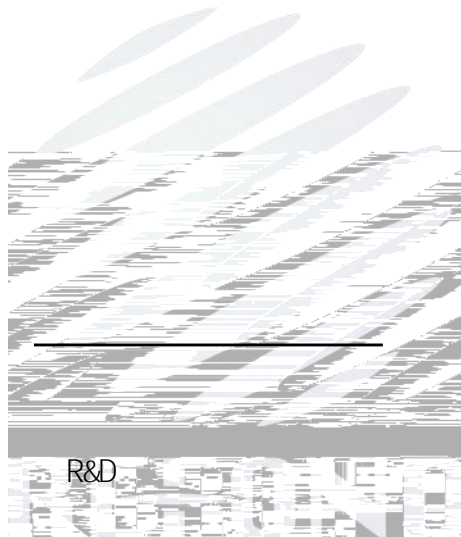
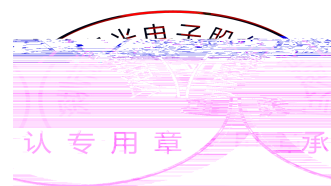

1. Description

1.1

1.2 Features

1.3 Application

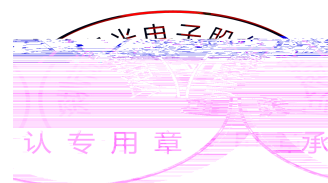

1.4 Package Dimension

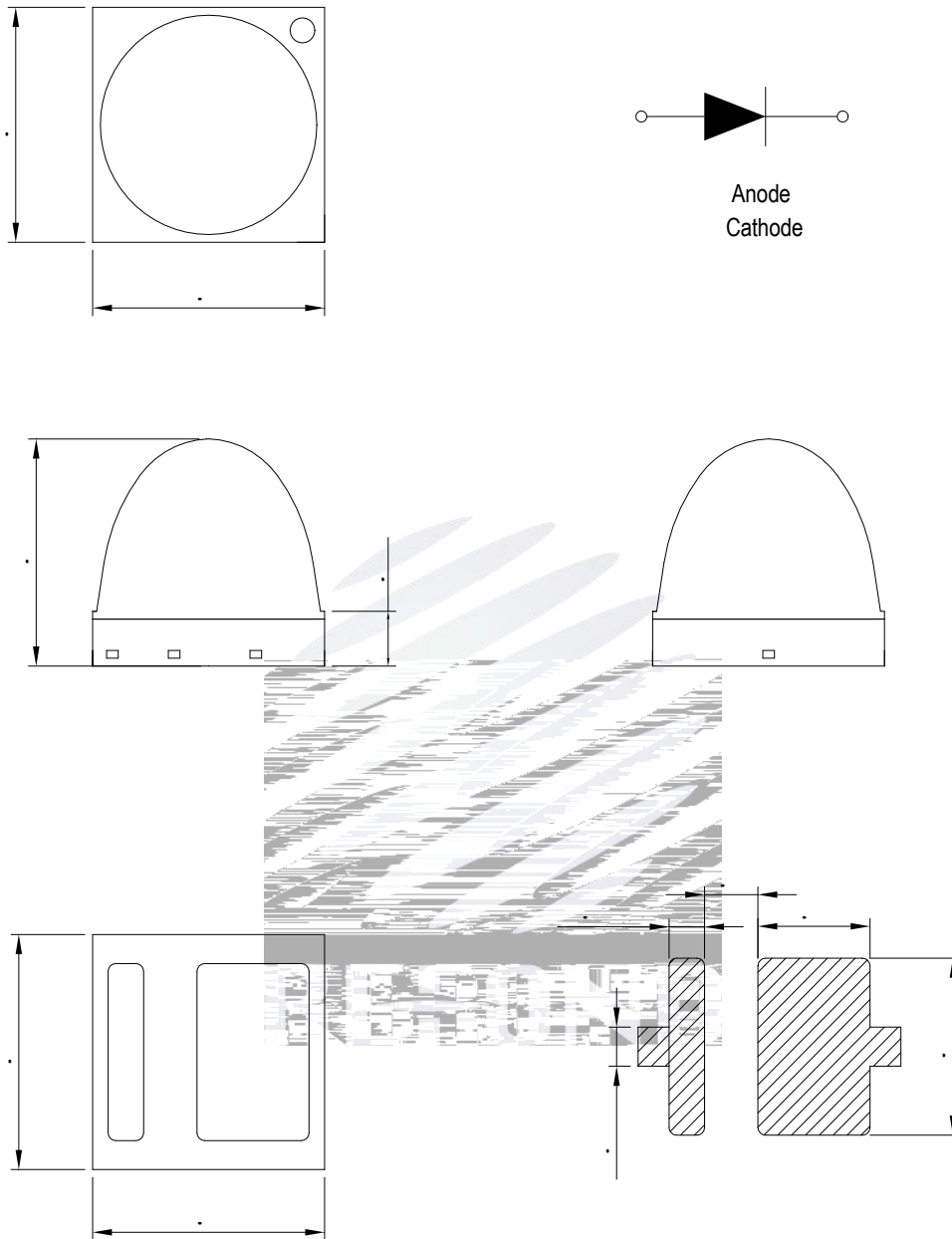

1.

±

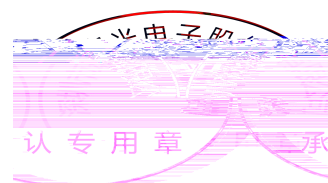

± 0.2

1.5 Product Parameters

()			

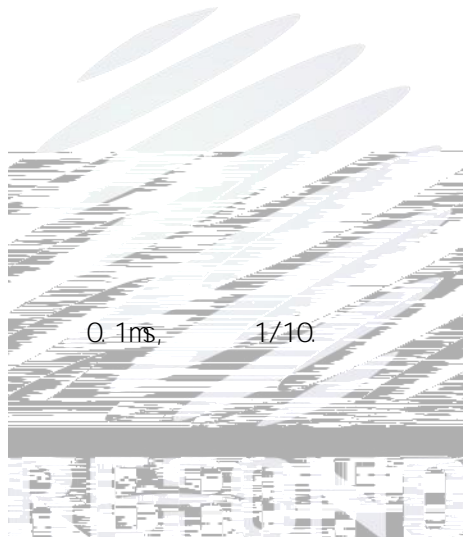

± 0.1V.

1.6 Bin Range Of Forward Voltage and Luminous Flux (IF=350mA)

BIN (IF=350mA)

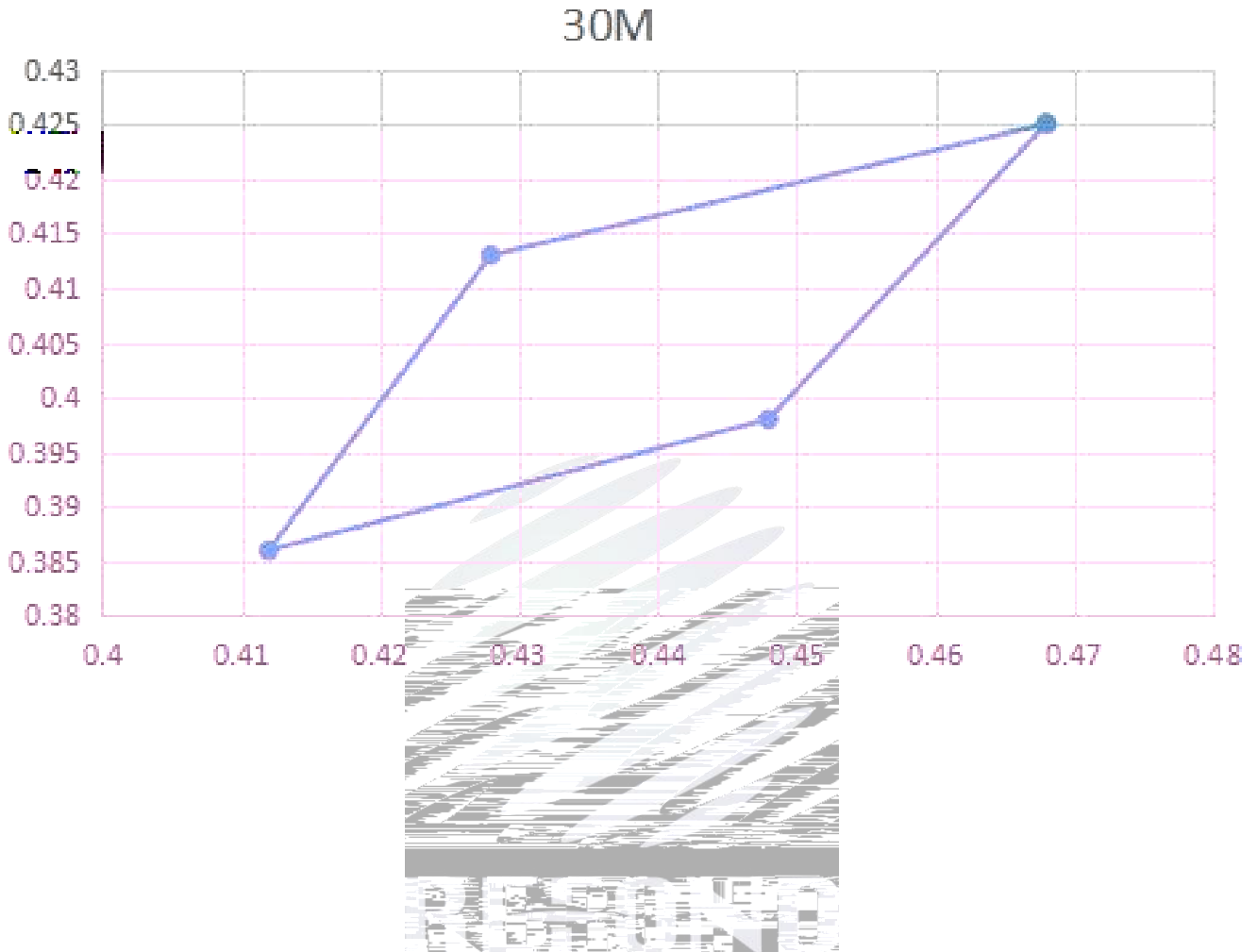

Bin data

Bin Code	X1	Y1	X2	Y2	X3	Y3	X4	Y4
30M	0.468	0.425	0.428	0.413	0.412	0.386	0.448	0.398

1.7 Typical Optical Characteristics Curves

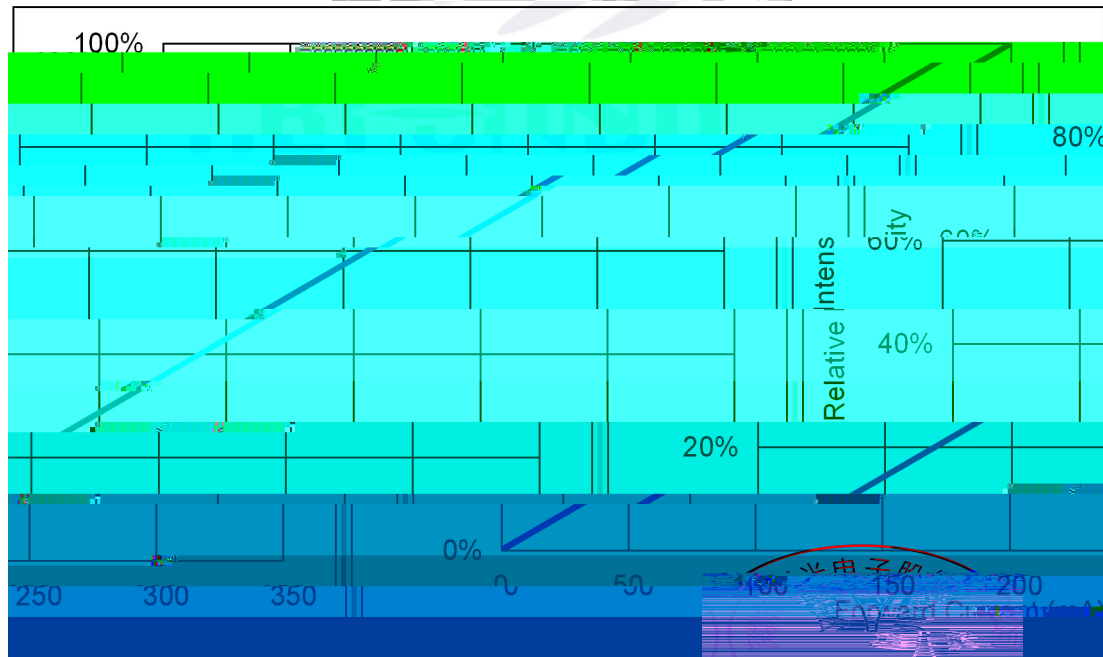
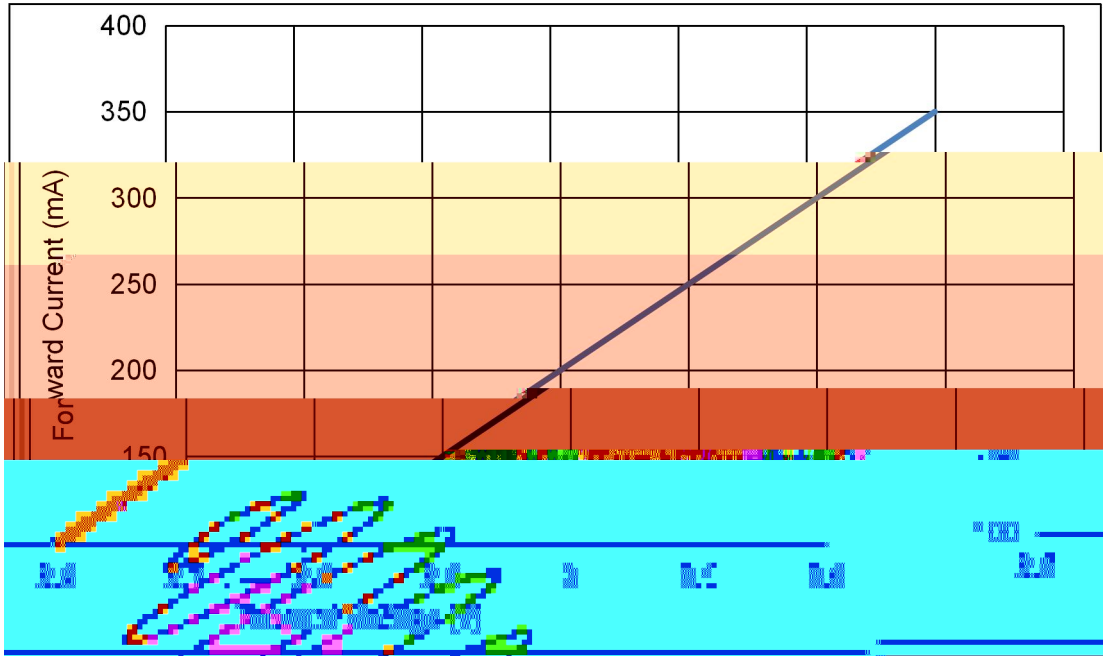

認專用章 承

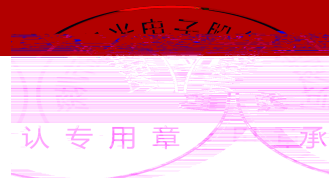
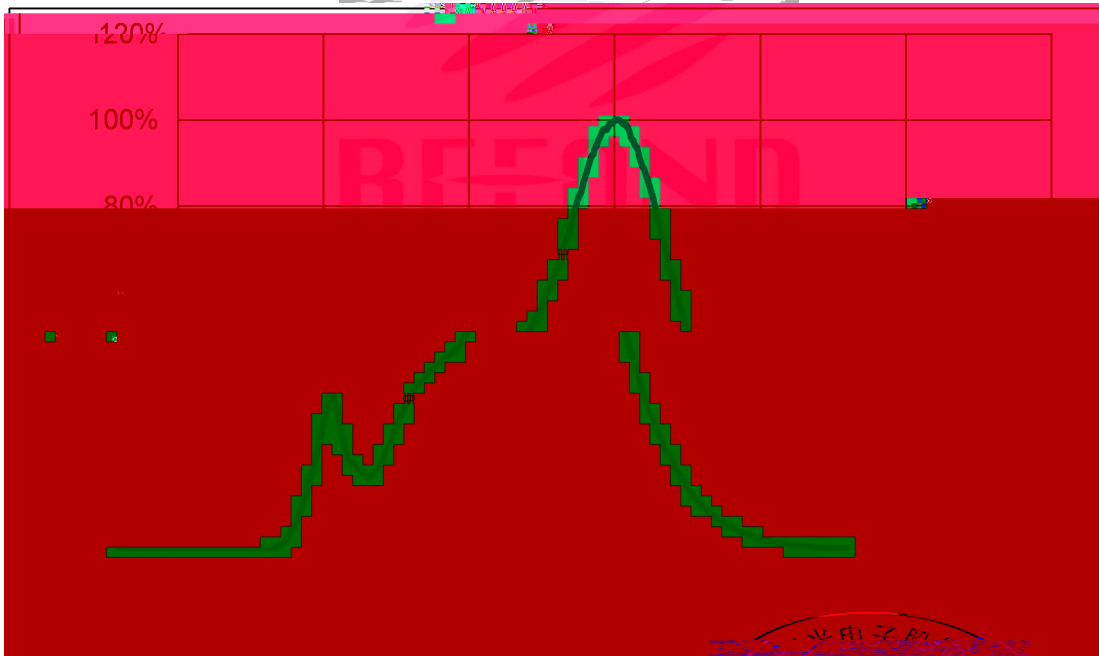
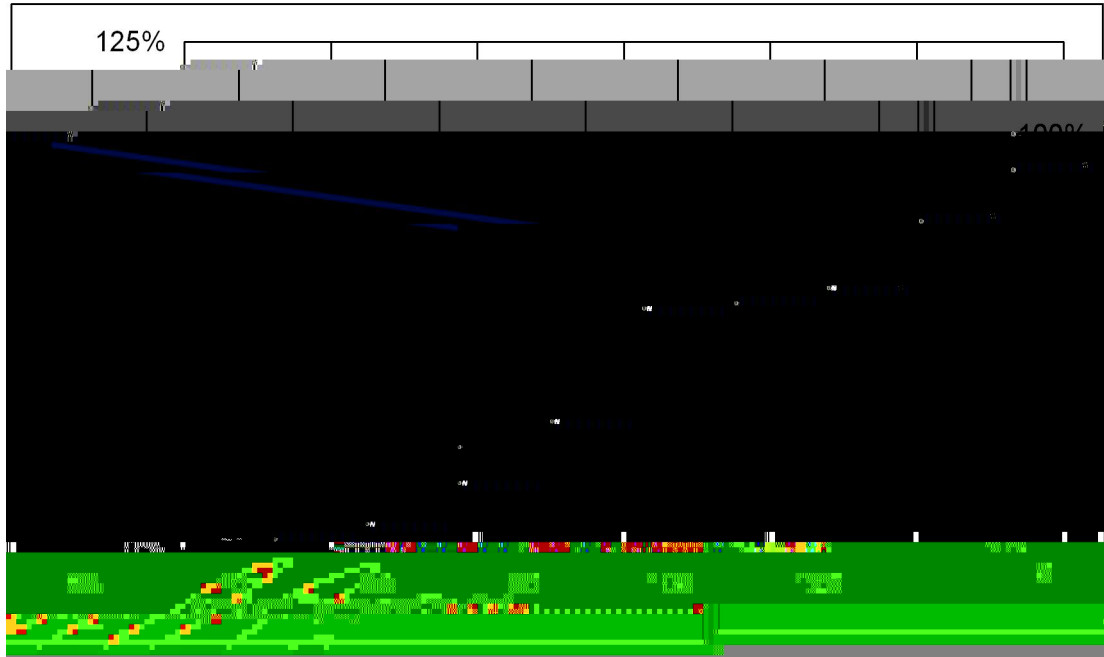

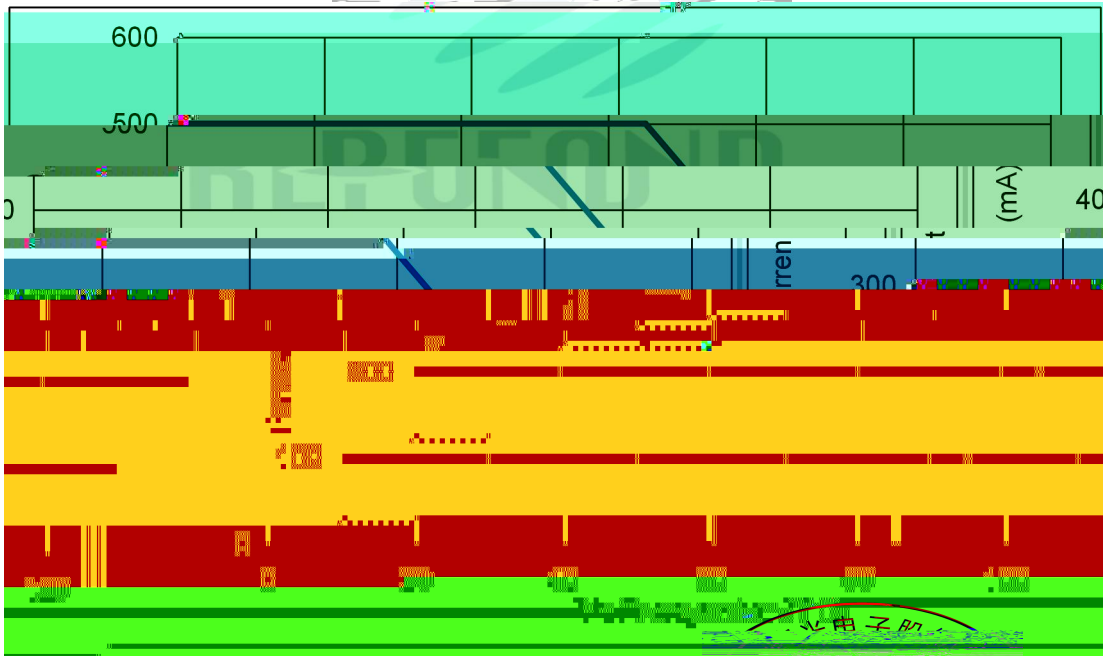
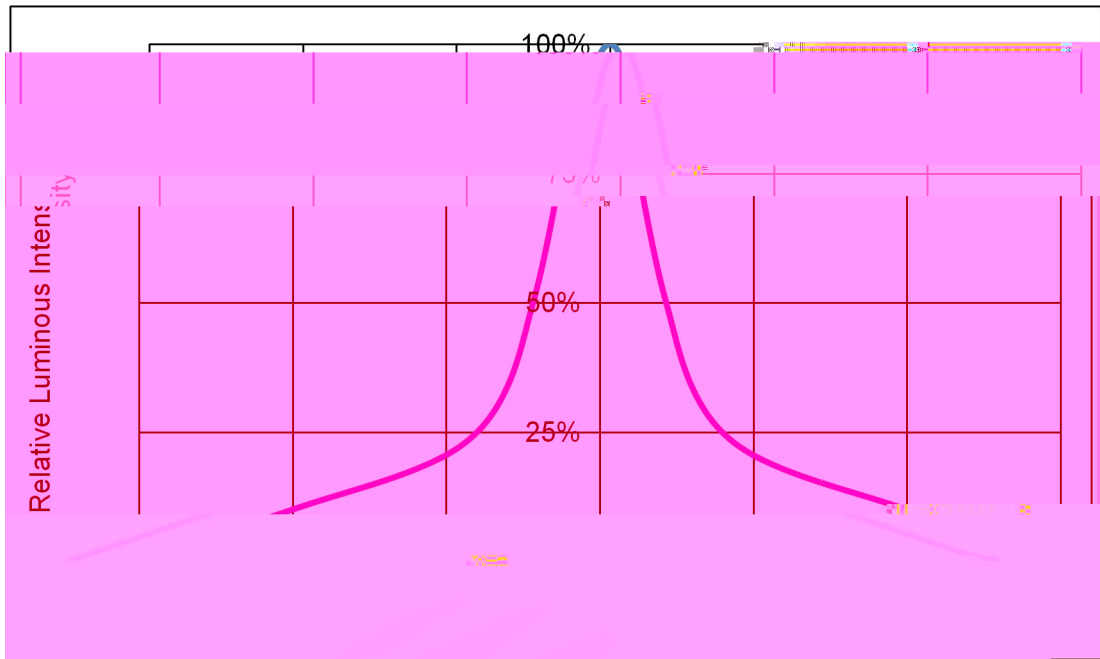

2. Packaging

2.1 Packaging Specification

2500pcs

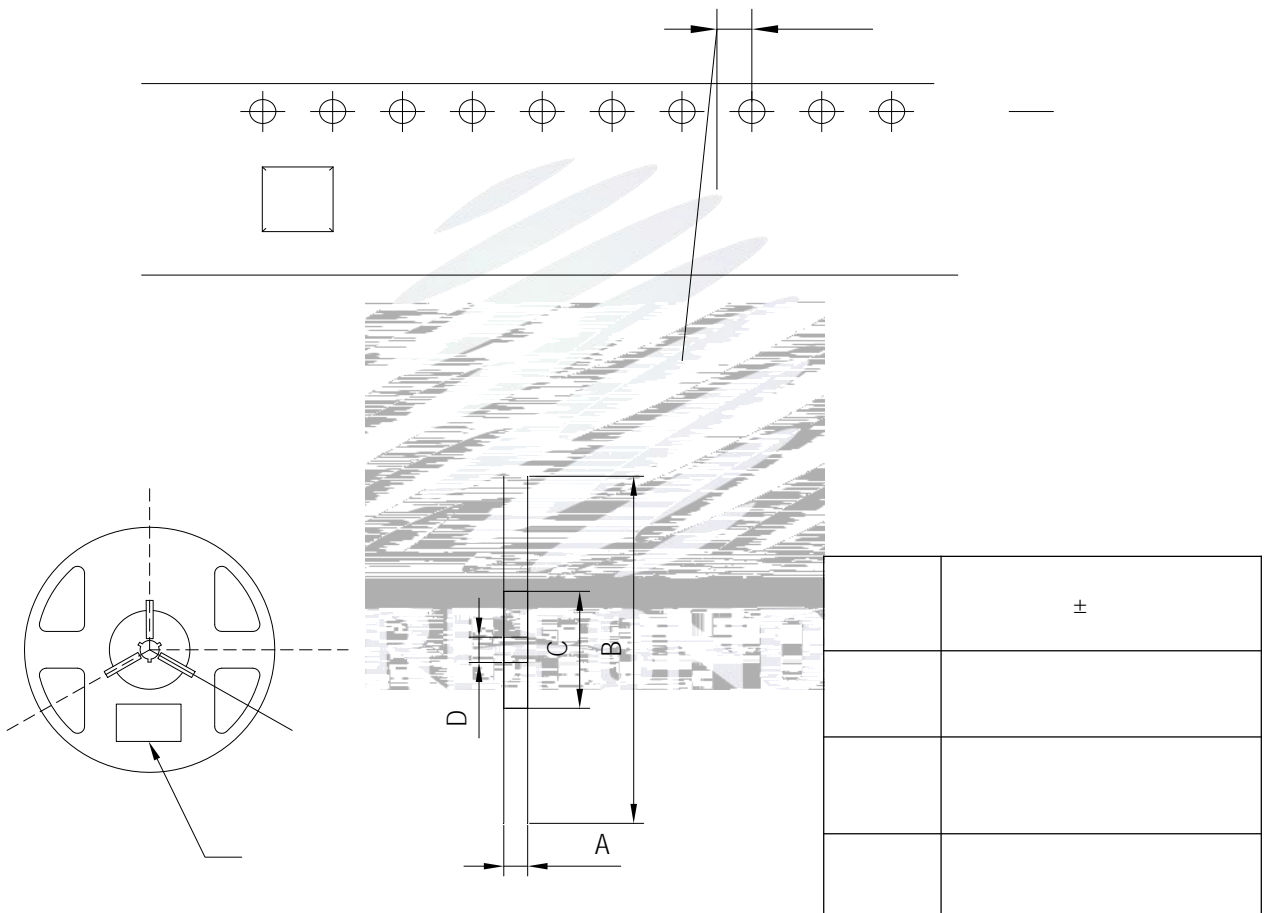

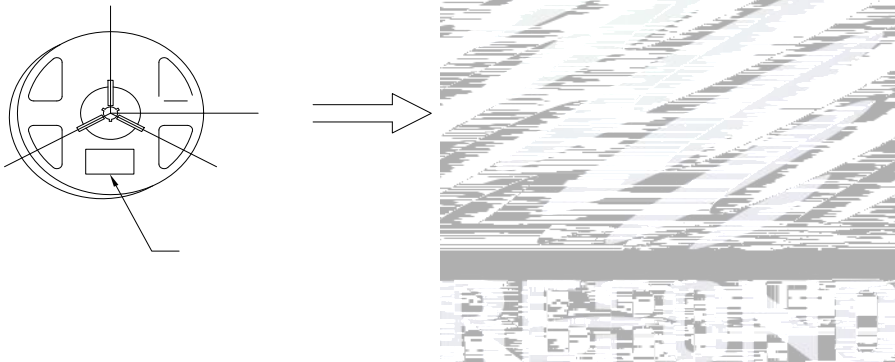

2.5 Criteria For Judging Damage

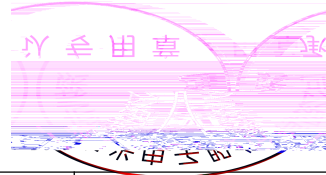

Luminous Flux				



LED

/ LED

è

3. SMT Reflow Soldering Instructions SMT

3.1 SMT Reflow Soldering Instructions SMT

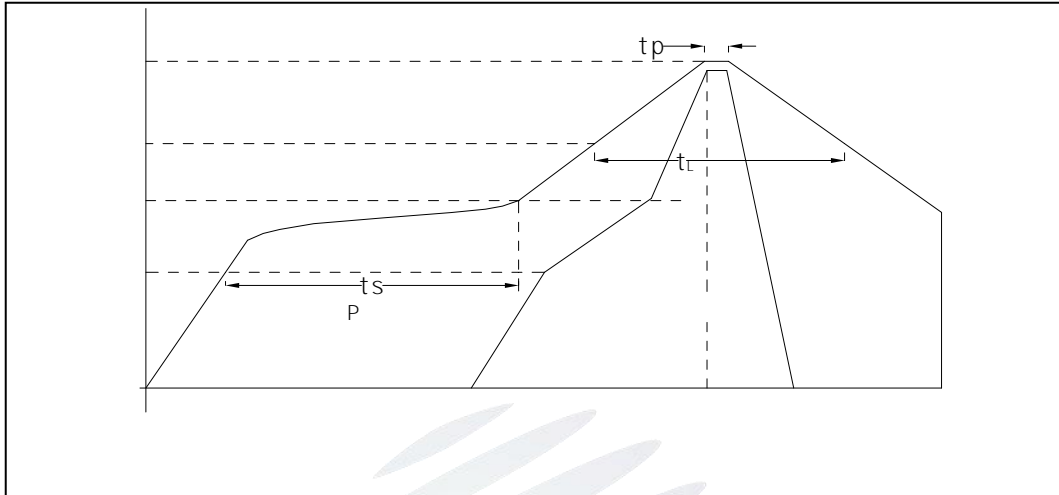

LED

(2)



(1)

LED

LED

PCB

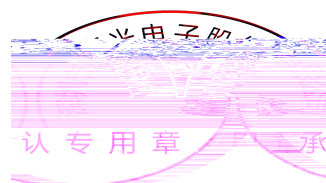

4. Handling Precautions

4.1 Handling Precautions

LED

100PPM

LED

LED

900PPM

900PPM

1500PPM



LED

LED

LED

LED

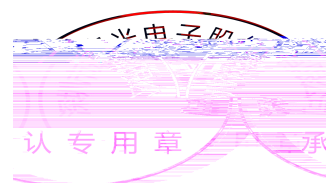



人。E



W

))

ETM

