

SPECIFICATION 产品规格书

REFOND P/N 产品型号

RF-IC30807TS-H01-B0

R&D 研发

Mass Product 量产供货



Contents 目录

1. Description 产品介绍	
1.1 General Description 产品描述	
1.2 Features 产品特征	
1.3 Application 应用领域	
1.4 Package Dimension 封装尺寸	
1.5 Product Parameters 产品参数	
1.6 Application Information 应用信息	
1.6.1 Chip Forwarding Code Type Parameters 芯片转发码型参数 (VDD = 5 V, Ta = 25°C)	7
1.6.2 Controller Sends Code Type Parameters 控制器发送码型参数 (VDD = 5 V, Ta = 25°C)	7
1.6.3 Data Transmission Mode 数据传输方式	8
1.6.4 Typical Application Line 典型应用线路	8
2. Packaging 产品包装	
2.1 Packaging Specification 包装规格	
2.1.1 Carrier Tape Dimension 载带尺寸	9
2.1.2 Reel Dimension 卷盘尺寸	9
2.1.3 Label Form Specification 标签规格	10
2.2 Moisture Resistant Packing 防潮包装	
2.3 Cardboard Box 包装纸箱	
2.4 Reliability Test Items And Conditions 信赖性测试项目及条件	
2.5 Criteria For Judging Damage 失效判定标准	
3. SMT Reflow Soldering Instructions SMT 回流焊说明	
3.1 SMT Reflow Soldering Instructions SMT 回流焊说明	
4. Handling Precautions 产品使用注意事项	
4.1 Handling Precautions 产品使用注意事项	



1. Description 产品介绍

1.1 General Description 产品描述

The Colour LED which was fabricated using blue, green and orange chip, Package Dimension : 2.0mmX1.7mmX0.7mm.

该产品由蓝光、绿光和橙光晶片封装形成。产品尺寸：2.0mmX1.7mmX0.7mm。

1.2 Features 产品特征

The three primary colors of each pixel can achieve 256level brightness display. 每个像素点的三基色颜色可实现256级亮度显示。

A single power supply transmits digital signals simultaneously. 单线供电同时传输数字信号。

Suitable for all SMT assembly and solder process. 适用于所有的SMT组装和焊接工艺。

Moisture sensitivity level: Level 3. 防潮等级 Level3

RoHS compliant. 符合 RoHS

The color of light is highly consistent and cost-effective. 光的颜色高度一致，性价比高

1.3 Application 产品应用

Article color lamp, lamp belt. 彩色灯条、灯带

Landscape lighting Trademark logo. 景观照明，招牌字

General indoor uses. 其他室内应用



1.4 Package Dimension 封装尺寸

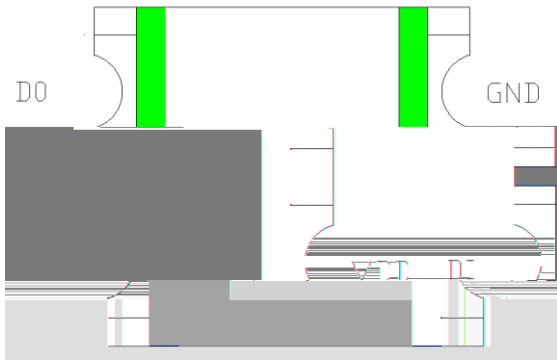

Fig.1-1 Top view 正面视图

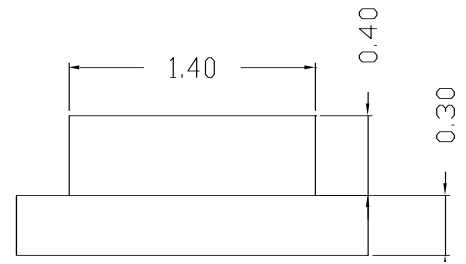

Fig.1-2 Side view 侧面视图

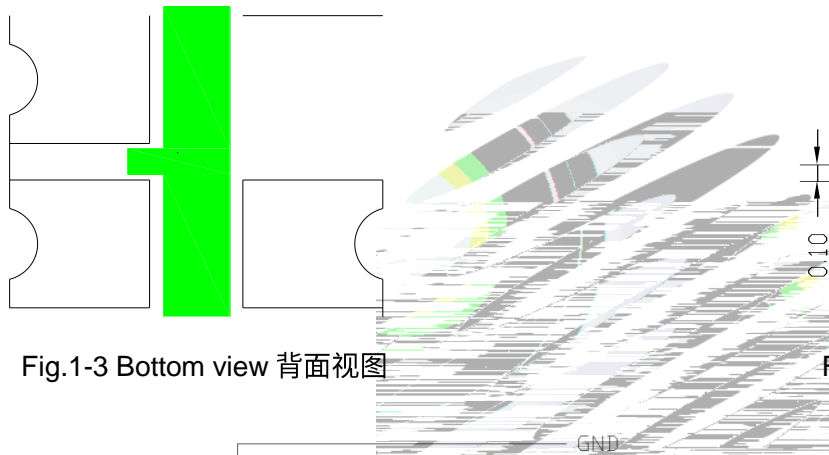

Fig.1-3 Bottom view 背面视图

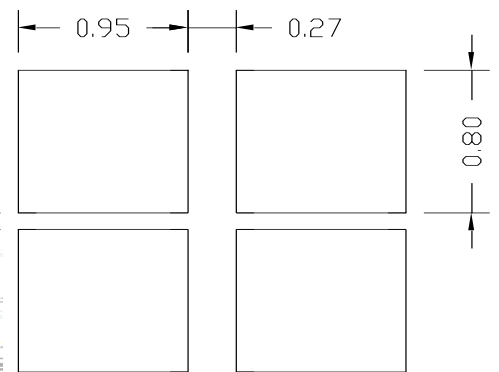

Fig.1-5 Soldering patterns 推荐焊盘

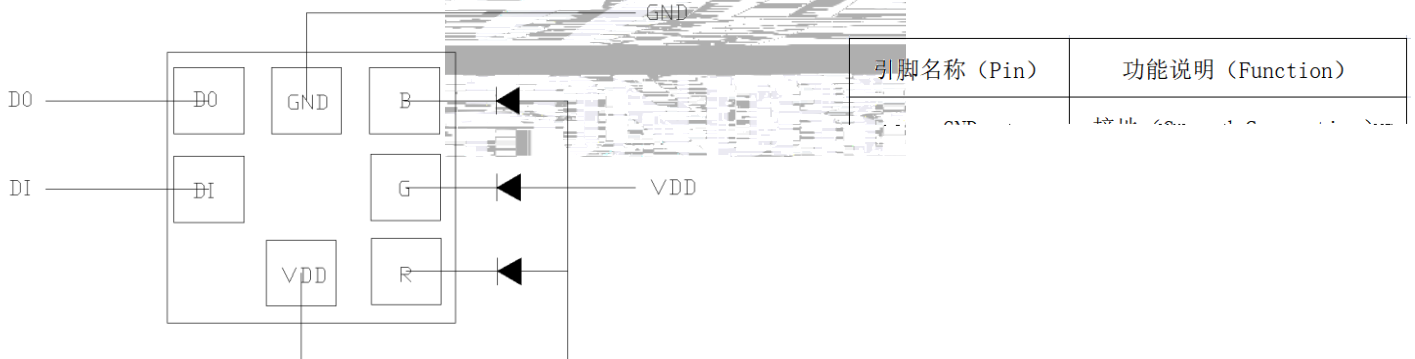

Fig.1-4 Polarity 极性

Notes 备注

1. All dimensions units are millimeters. 所有尺寸标注单位为毫米

All dimensions tolerances are 0.2mm unless otherwise noted. 除特别标注外, 所有尺寸公差为±0.2 毫米



1.5 Product Parameters 产品参数

Table 1-1 Electrical / Optical Characteristics at Ts=25°C 电性与光学特性

Item 项目	Test Condition 测试条件	Symbol 符号	Value			Unit 单位	
			Min. (最小值)	Typ. (典型值)	Max. (最大值)		
Dominant wavelength 主波长	VDD=5V	d		620	--	630	nm
			G	520	--	530	
			B	465	--	475	
Luminous Intensity 发光强度		lv	O	50	--	300	mcd
			G	200	--	700	
			B	50	--	300	

Notes

- 1/10 Duty cycle, 0.1ms pulse width.  0.1ms, 1/10.
- The above forward voltage measurement allowance tolerance is $\pm 0.1V$. $\pm 0.1V$.
- The above dominant wavelength measurement allowance tolerance is $\pm 2nm$. $\pm 2nm$.
- The above luminous intensity measurement allowance tolerance $\pm 10\%$. $\pm 10\%$.
- Care is to be taken that power dissipation does not exceed the absolute maximum rating of the product.
- All measurements were made under the standardized environment of Refond.
- When the LEDs are in operation the maximum current should be decided after measuring the package temperature, junction temperature should not exceed the maximum rate. LED



Table 1-2 Absolute Maximum Ratings at Ts=25°C 绝对最大值

Parameter (参数)	Symbol (符号)	Rating (值)	Units (单位)
Logic Supply Voltage (逻辑电源电压)	VDD	-0.5-5.5	V
DIN Port Voltage (DIN 端口电压)	V _{DI}	-0.5-VDD+0.5	V
OUT Port Voltage (OUT 端口电压)	OUT R/G/B 端口耐压	13	V
Operating Temperature (操作温度)	T _{opr}	-40 ~ +85	°C
Storage Temperature (储存温度)	T _{stg}	-40 ~ +85	°C

Table 1-3 Recommended Operating Condition 推荐工作条件 (-40-85°C)

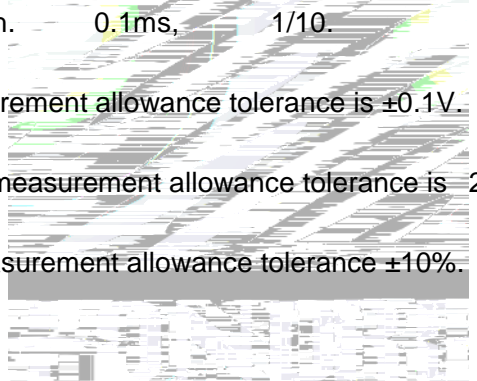
Parameter (参数)	Symbol (符号)	Rating (值)	Units (单位)
supply voltage (电源电压)	VDD	3.5-5.5	V

Table 1-4 Recommended Operating Condition 推荐工作条件 (VDD=5.0V, TA=+25°C)

Parameter (参数)	Symbol (符号)	Min	Typ	Max	Units (单位)
Working current (工作电流)	I _{DD}		0.5		mA
Driving current (R/G/B 驱动电流)	I _{LED01}		12		mA
High-Level Input Voltage (高电平输入电压)	V _{IH}	0.65VDD			V
Low-Level Input Voltage (低电平输入电压)	V _{IL}			0.3VDD	V



1.6 Application Information 应用信息

Fig.1-15 交流参数示意图

1.6.1 Chip Forwarding Code Type Parameters 芯片转发码型参数 (VDD = 5 V, Ta = 25°C)

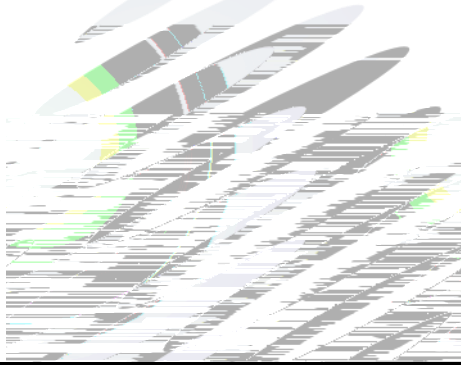

码元周期	T_{DATA}	1.2	1.25	-	us
0 码高电平时间	T_{OH}	0.26	0.33	0.40	us
0 码低电平时间	T_{OL}	-	0.92	-	us
1 码高电平时间	T_{1H}	0.58	0.66	0.75	us
1 码低电平时间	T_{1L}	-	0.59	-	

1.6.3 Data Transmission Mode 数据传输方式

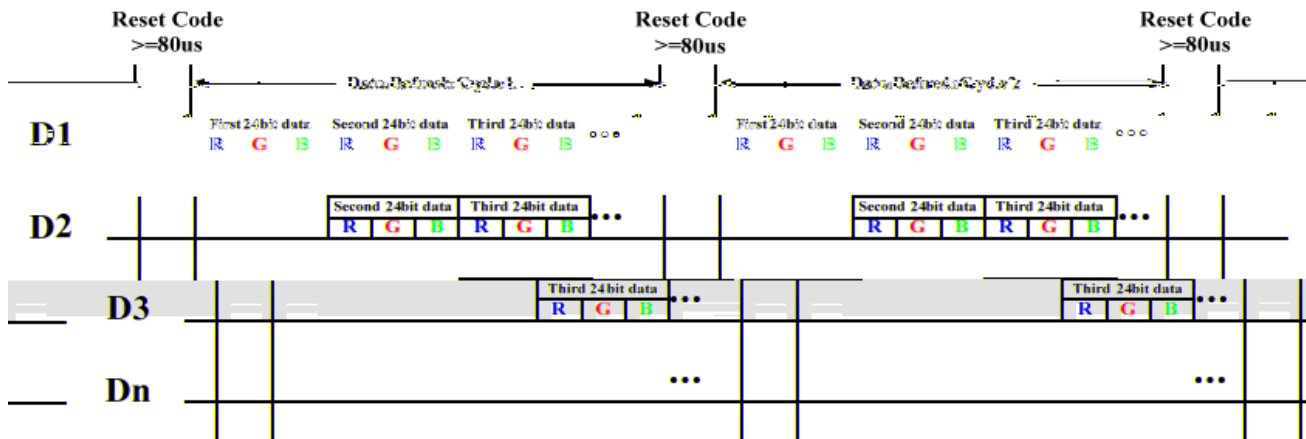

其中 D1 为 MCU 端发送的数据，D2、D3、Dn 为级联芯片自动整形转发的数据。

1.6.4 Typical Application Line 典型应用线路

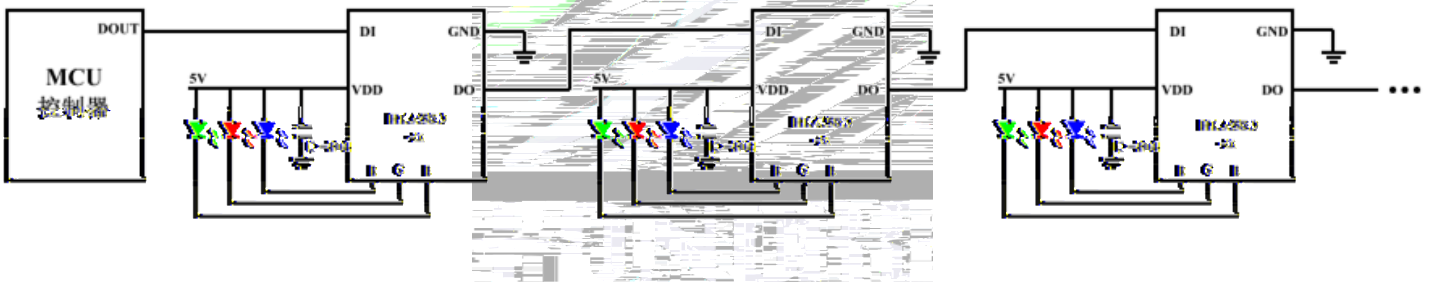

为防止 MCU 的 GND 与灯带 GND 有地弹现象，建议第一颗灯珠的 DI 串入 300 ~1K 电阻。



2. Packaging 产品包装

2.1 Packaging Specification 包装规格

Package:4000pcs/reel.包装每卷 4000pcs。

2.1.1 Carrier Tape Dimension 载带尺寸

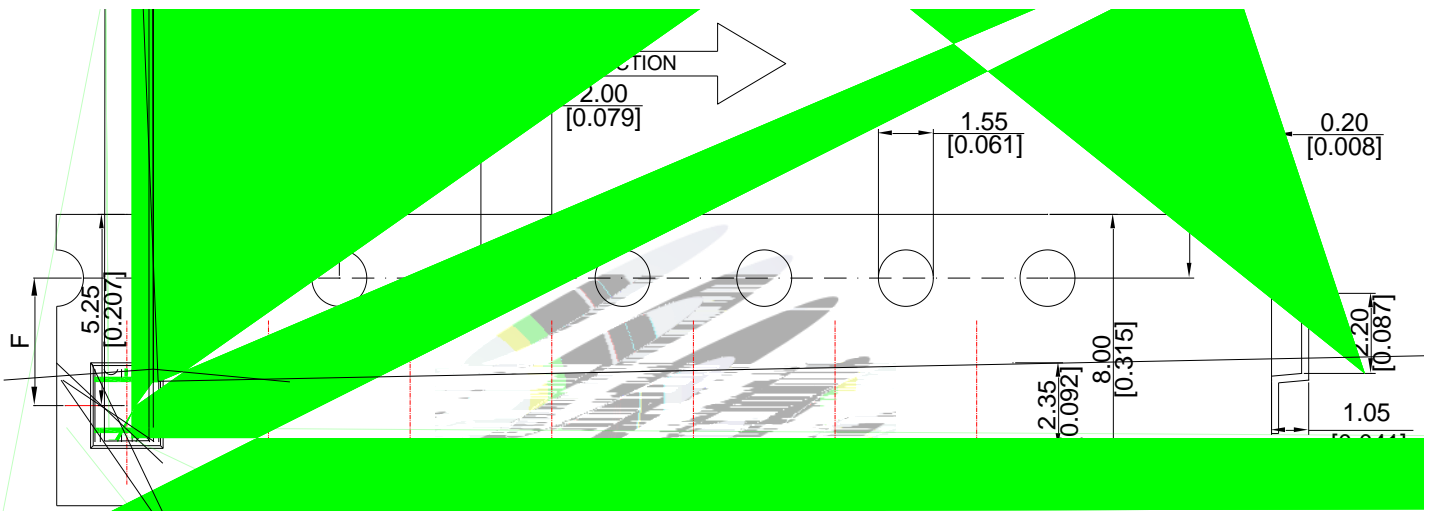
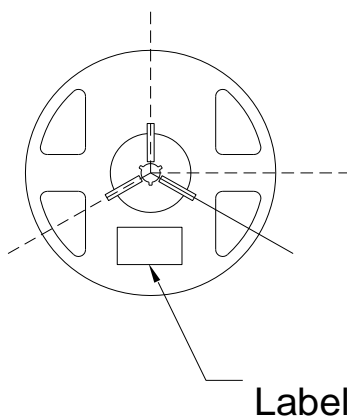

Fig.2-1 Carrier Tape Dimension 载带尺寸

2.1.2 Reel Dimension 卷盘尺寸



Label 标签

Fig.2-2 Reel Dimension 卷盘尺寸

Table 2-1 Dimension 尺寸

A	8.0±0.1mm
B	178±1mm
C	60±1mm
D	13.0±0.5mm

Notes 备注:

The tolerances unless mentioned ±0.1mm. Unit : mm 注：未注公差为±0.1毫米，尺寸单位：毫米。

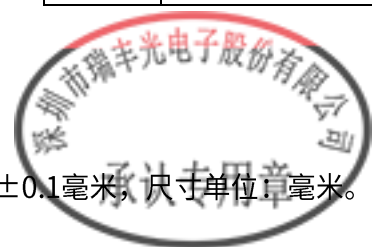

2.1.3 Label Form Specification 标签规格



Table 2-2 Parameter 参数

PART NO.	Part Number 品名
SPEC NO.	Spec Number 规格
LOT NO.	Lot Number 批次号
BIN CODE	Bin Code 参数代码
	Luminous flux 光通量
XY	Chromaticity Bin 色区
V _F	Forward Voltage 正向电压
WLD	Wavelength 波长代码
QTY	Packing Quantity 数量
DATE	Made Date 生产日期

Fig. 2-3 Label Form Specification 标签规格

2.2 Moisture Resistant Packing 防潮包装

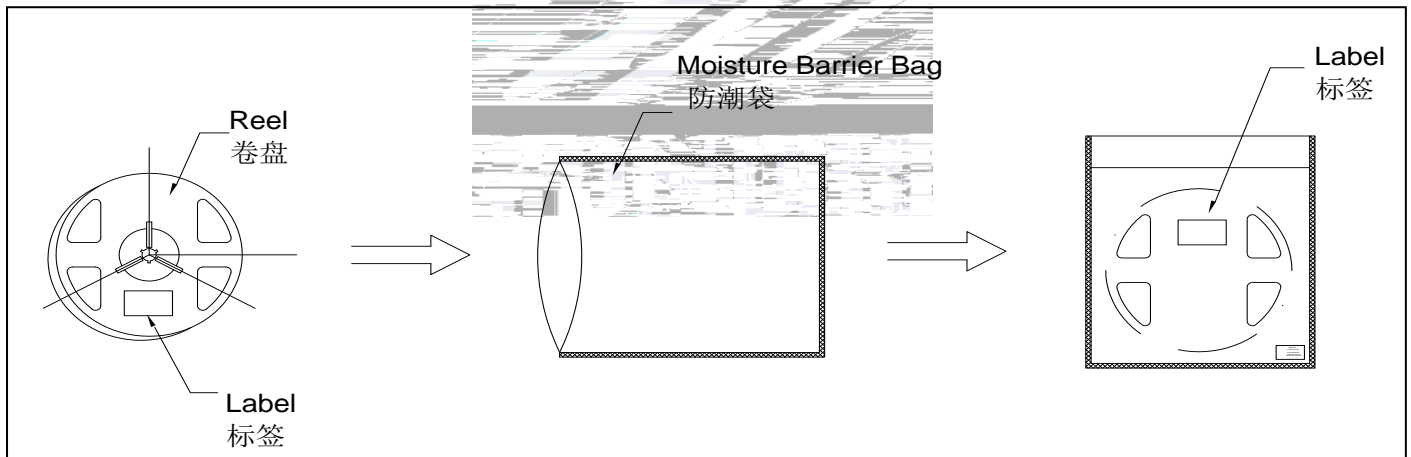

Fig.2-4 Moisture Resistant Packing 防潮包装



2.3 Cardboard Box 包装纸箱

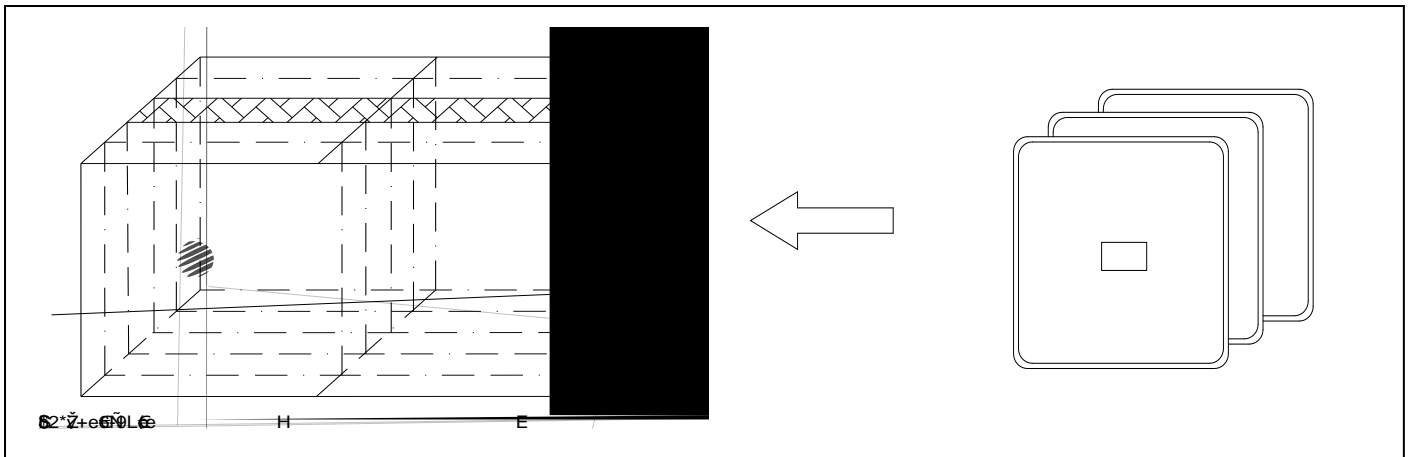
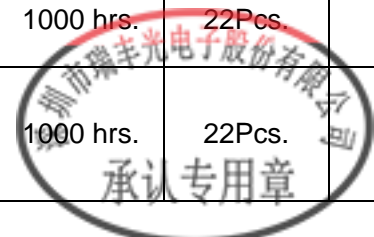

Fig.2-5 Cardboard Box 包装纸箱

2.4 Reliability Test Items And Conditions 信赖性测试项目及条件

Table 2-3 Reliability Test Items And Conditions 信赖性测试项目及条件

Test Items 项目	Ref.Standard 参考标准	Test Condition 测试条件	Time 时间	Quantity 数量	Ac/Re 接收/拒收
Reflow 回流焊	JESD22-B106	Temp:260°Cmax T=10 sec	2 times	22Pcs.	0/1
Temperature Cycle 温度循环	JESD22-A104	100°C 30 min 5 min -40°C 30 min	300 cycles	22Pcs.	0/1
Thermal Shock 冷热冲击	JESD22-A106	-40°C 15min 100°C 15min	300 cycles	22Pcs.	0/1
High Temperature Storage 高温保存	JESD22-A103	Temp:100°C	1000 hrs.	22Pcs.	0/1
Low Temperature Storage 低温保存	JESD22-A119	Temp:-40°C	1000 hrs.	22Pcs.	0/1
Life Test 常温通电	JESD22-A108	T _a =25°C I _F =5mA	1000 hrs.	22Pcs.	0/1



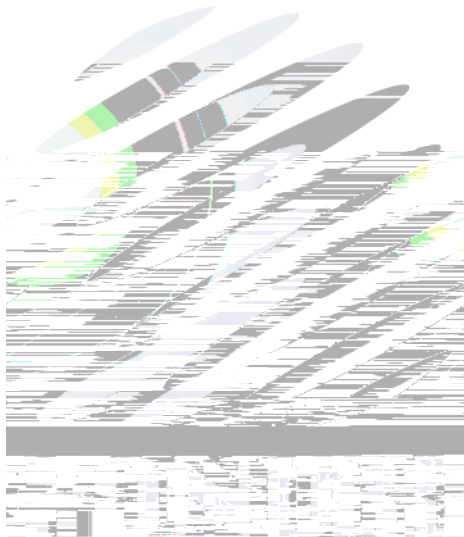

3. SMT Reflow Soldering Instructions SMT

3.1 SMT Reflow Soldering Instructions SMT 回流焊说明

Fig.3-1 SMT Reflow Soldering Instructions SMT 回流焊说明

Table 3-1 Parameter 参数

Average temperature rise speed 平均升温速度 (T _{max} 至 T _P)	最高3 °C/秒 Max 3 °C/ s
Preheating: minimum temperature 预热: 最低温度 (T _{min})	150 °C
Preheating: Max temperature 预热: 最高温度 (T _{max})	200 °C
Preheating: Time 预热: 时间 (T _{min} 至 T _{max})	60 - 120秒

Notes 备注

(1)Reflow soldering should not be done more than twice. If more than 24 hours between the two solderings , LED will be damaged. 回流焊次数不可以超过两次，两次回流焊的时间间隔如果超过 24 小时，LED 可能由于吸湿而损坏。

(2)Whensoldering , do not put stress on the LEDs during heating 当焊接时，不要在材料受热时用外力挤压表面。

3.1.1 Soldering Iron 烙铁焊接

(1) When do soldering by hand, keep the temperature of iron below less 300°C less than 3 seconds. 当手工焊接时,烙铁的温度必须小于300°C，时间不可超过3秒。

(2) Soldering by hand should be done only one time.手工焊接只可焊接一次。

3.1.2 Repairing 维修

Repairing should not be done after the LEDs have been soldered. When repairing is unavoidable,a double-head soldering iron should be used (as below figure). It should be confirmed in advance whether the characteristics of LEDs will or not be damaged by repairing.

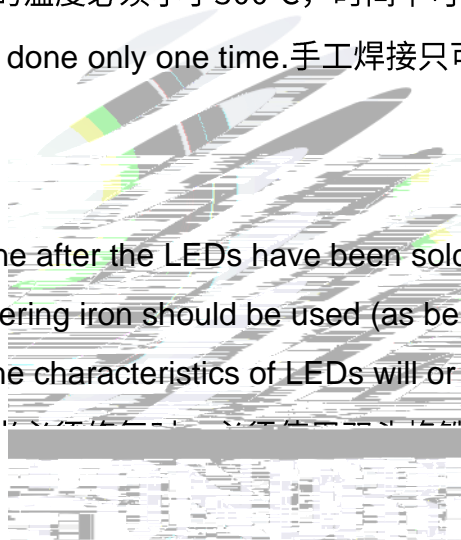

LED 维修可能会损坏 LED 本身的特性。

3.1.3 Cautions 注意事项

(1) Components should not be mounted on warped (non coplanar) portion of PCB. After soldering, do not warp the circuit board.LED 灯珠不要焊接在弯曲的 PCB 板上，焊接之后，也不要弯折线路板。

(2) Do not apply mechanical force or excess vibration during the cooling process to normal temperature after soldering. Do not rapidly cool device after soldering.回流焊之后冷却过程中，不要对材料施加外力，也不要有震动。回流焊后，不要采用急剧冷却的方式。





(4) In designing a circuit, the current through each LED can not exceed the absolute maximum rating specified for each LED. In the meanwhile, resistors for protection should be applied, otherwise slight voltage shift will cause big current change, burn out may happen. The driving circuit must be designed to allow forward voltage only when it is ON or OFF. If the reverse voltage is applied to LED, migration can be generated resulting in LED damage. 设计电路时, 通过 LED 的电流不能超过绝对最大额定值, 同时需加保护电阻, 否则电压微小波动会导致电流较大变化, 可能导致产品损毁。电路设计必须保证只有在开启或者关闭的时候出现正向电压的变化, 不要施加反压, 否则会损坏 LED。

(5) Thermal Design is paramount importance because heat generation may result in the Characteristics decline, such as brightness decreased, Color change and so on. Please consider the heat generation of the LEDs when making the system design. LED 容易因为自身的发热和环境的温度改变而改变, 温度升高会降低 LED 发光效率, 影响发光颜色, 所以在设计时应充分考虑散热问题。

(6) Storage 储存

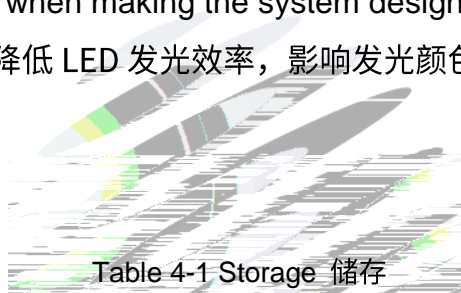
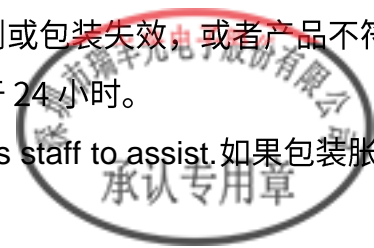

Table 4-1 Storage 储存

Conditions 种类		Temperature 温度	Humidity 湿度	Time 时间
Storage 储存	Before Opening Aluminum Bag 拆包前	≤30°C	≤75%	Within 1 Year From Date 一年内
	After Opening Aluminum Bag 拆包后	≤30°C	≤60%	168hours 168小时
Baking 烘烤		60±5°C	-	≥24hours 大于24小时

(7) If the moisture absorbent material silica gel has faded away or the LEDs have exceeded the storage time baking treatment should be performed after unpacking and based on the following condition 60±5 for above 24 hours. 如果干燥剂或包装失效, 或者产品不符合以上有效储存条件, 需拆包后进行烘烤, 烘烤条件: 60±5°C, 大于 24 小时。

If the package is flatulence or damaged, please notify the sales staff to assist. 如果包装胀气或者破损, 请及时告知销售人员协助处理。



(8) Similar to most Solid state devices; LEDs are sensitive to Electro-Static Discharge (ESD) and





Declare 申明

This specification is written both in English and in Chinese and the latter is formal.
产品规格书以中英文方式书写，若有冲突以中文版本为准。