

# SPECIFICATION

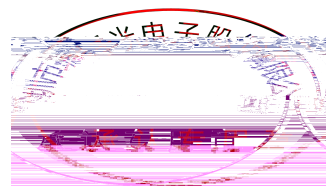

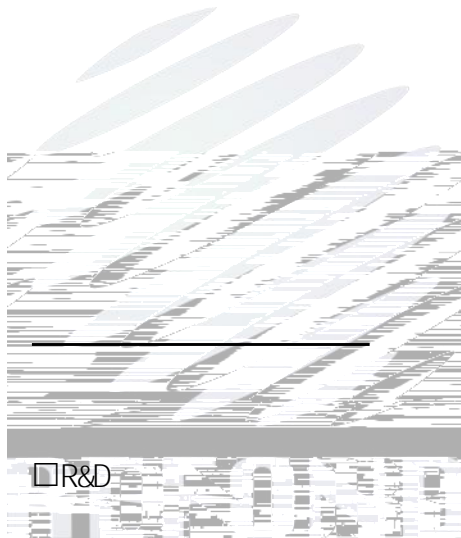
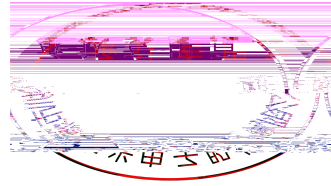

## 1. Description

### 1.1 General Description



### 1.2 Features



### 1.3 Application

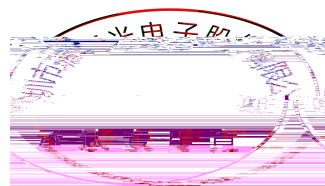

### 1.4 Package Dimension

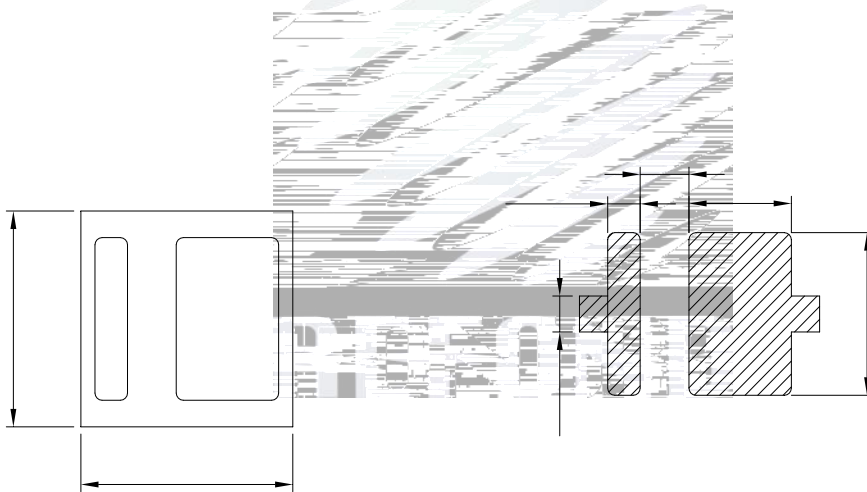
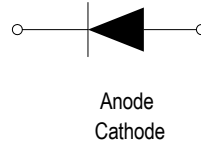
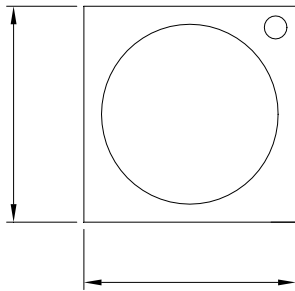

±

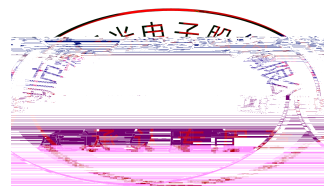

## 1.5 Product Parameters

	$\lambda$					

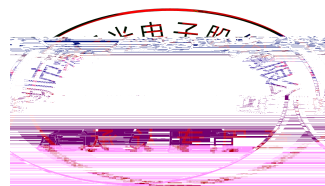

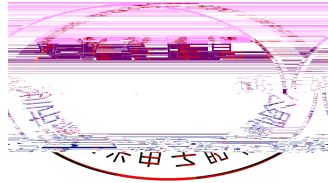

## 1.6 Typical optical characteristics curves

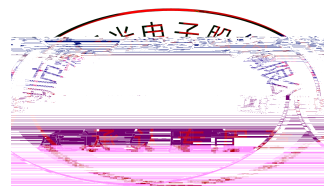
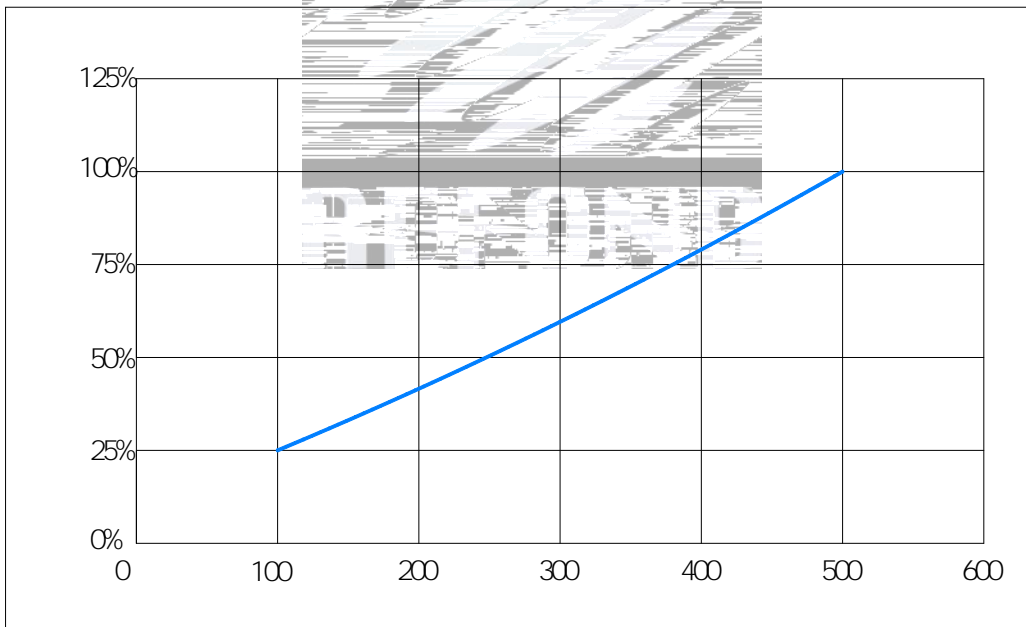
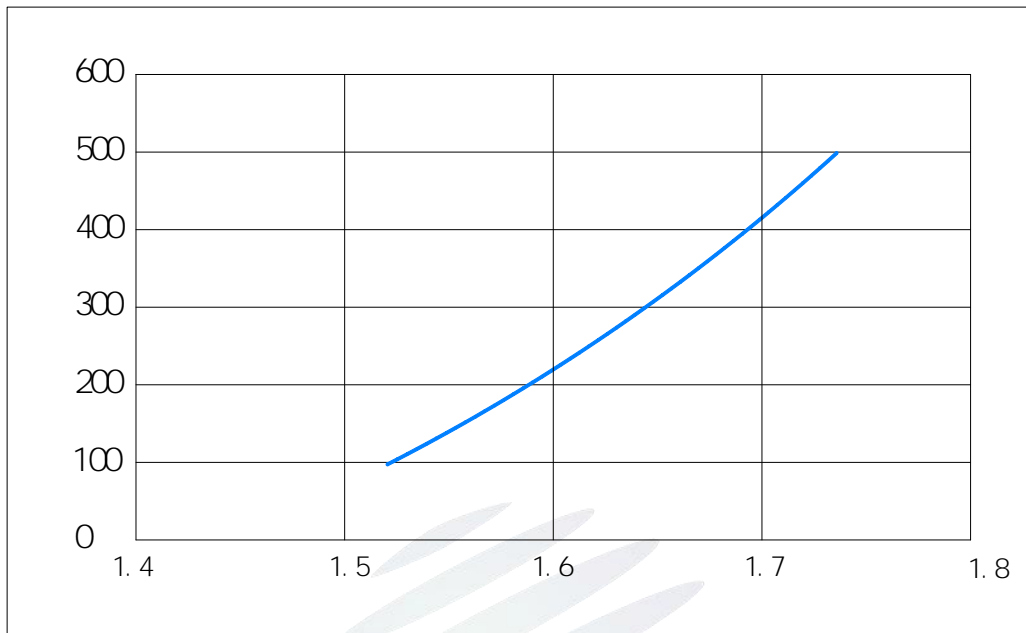

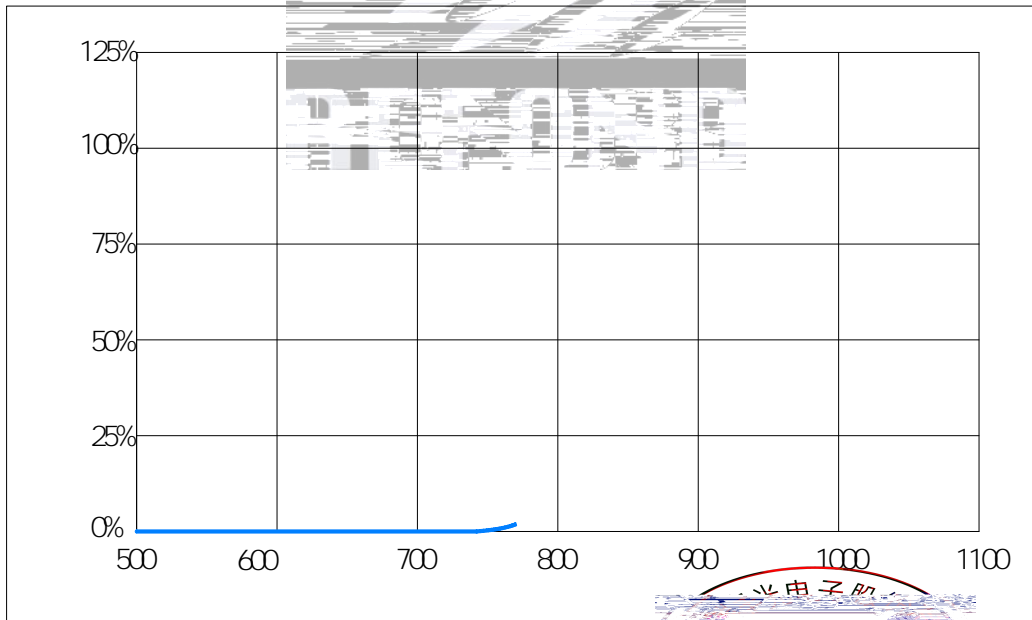
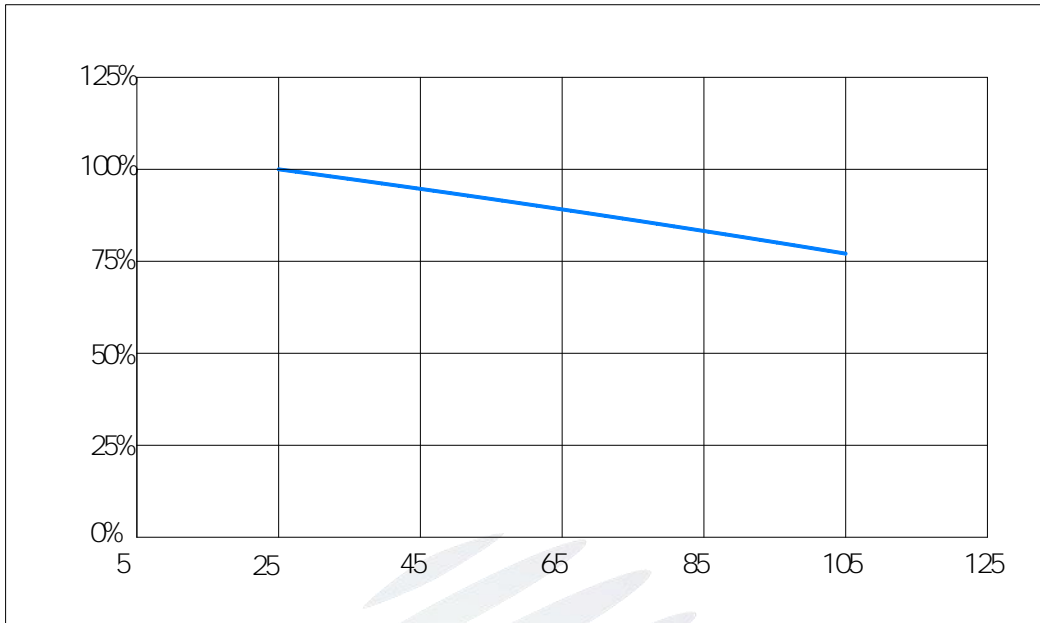



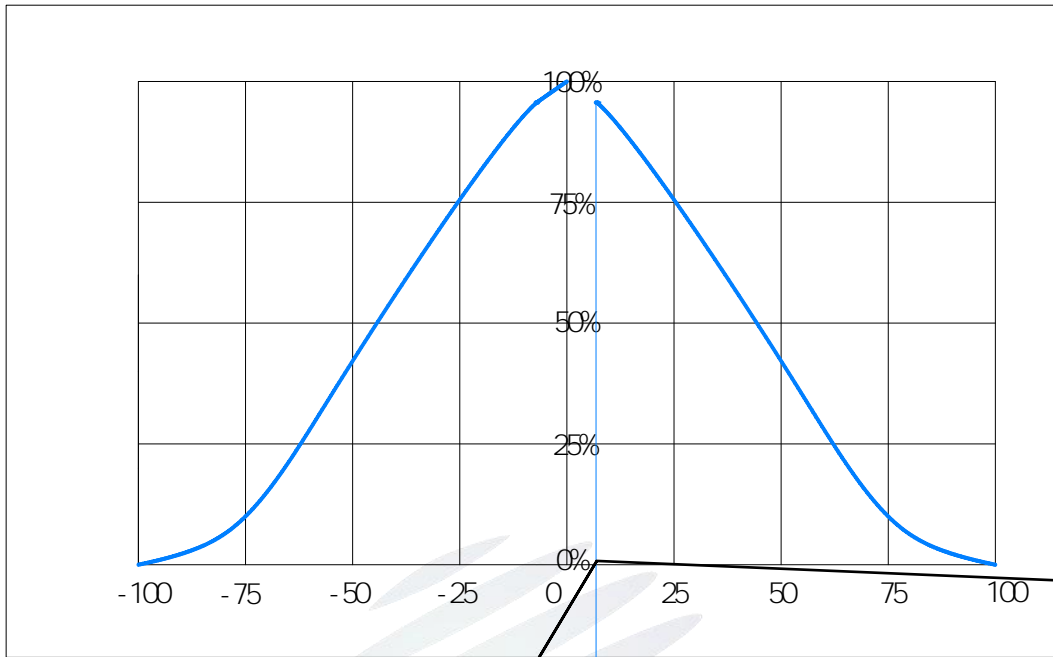





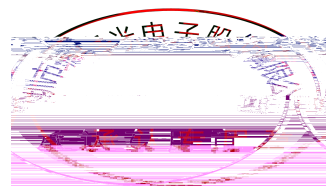
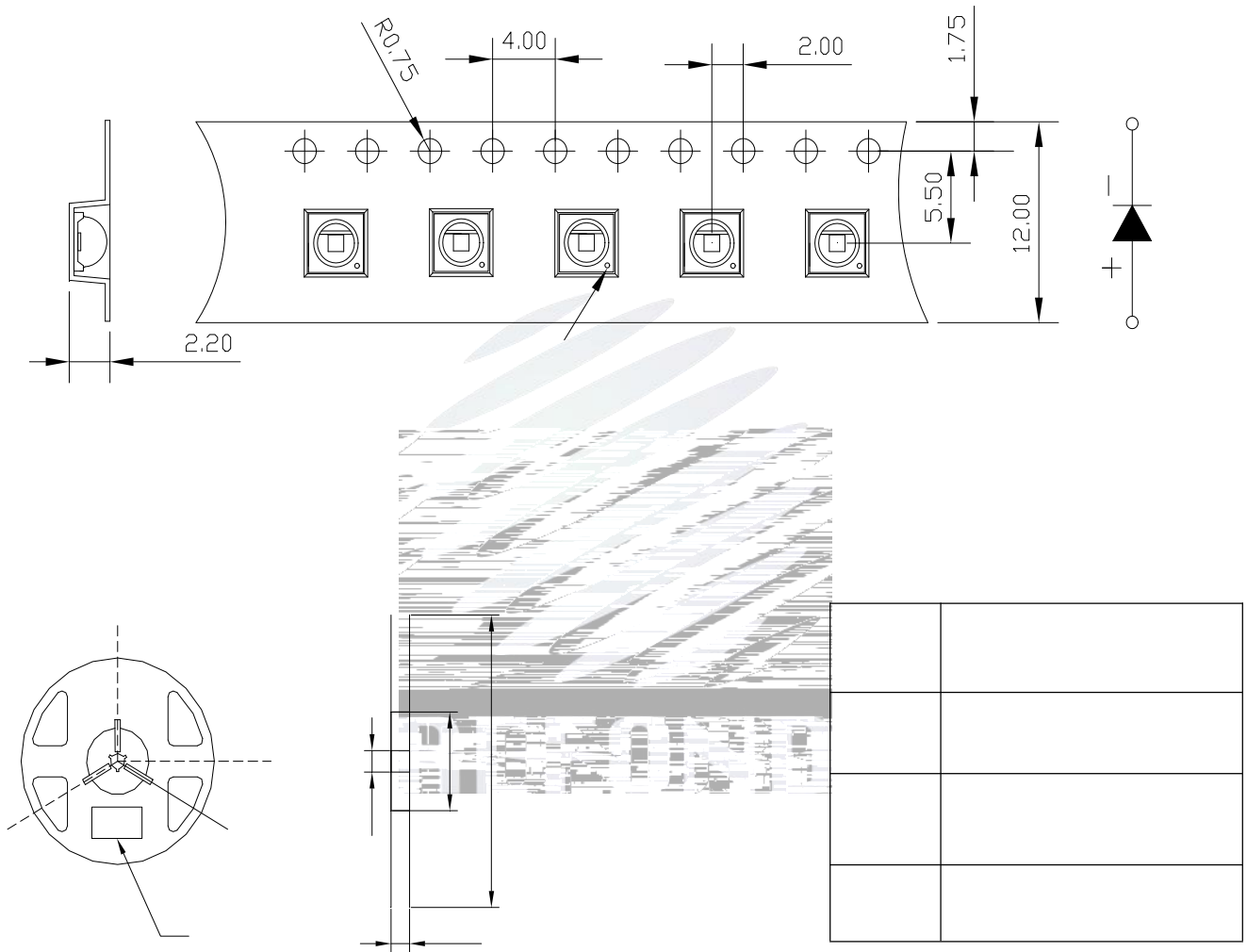

## 2. Packaging

### 2.1 Packaging Specification



PART NO.	
SPEC NO.	
LOT NO.	
BIN CODE	
e	WLP
VF	
	QTY:
	DATE:

---

---

---

---

---

---

---

---

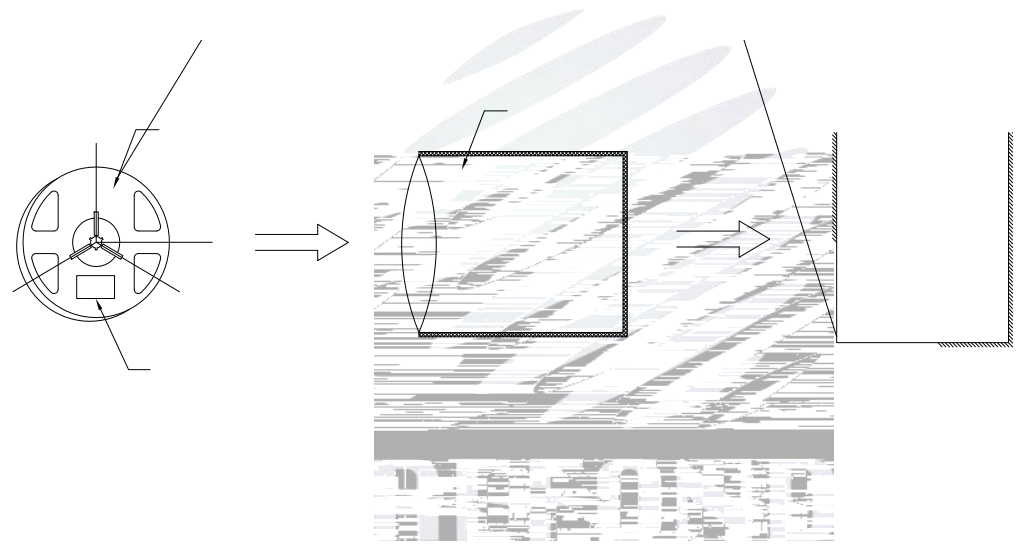

## 2.4 Reliability Test Items And Conditions

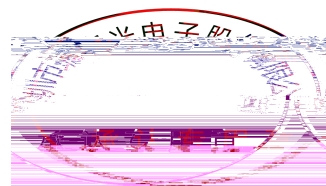
## 2.5 Criteria For Judging Damage

1.

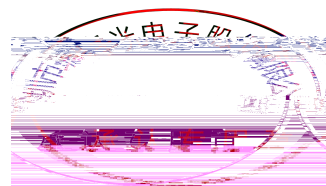

## 3. SMT Reflow Soldering Instructions

### 3.1 SMT Reflow Soldering Instructions

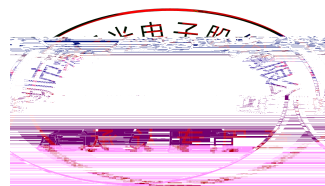

°C

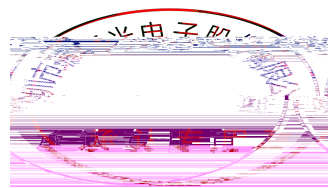

## 4. Handling Precautions

### 4.1 Handling Precautions

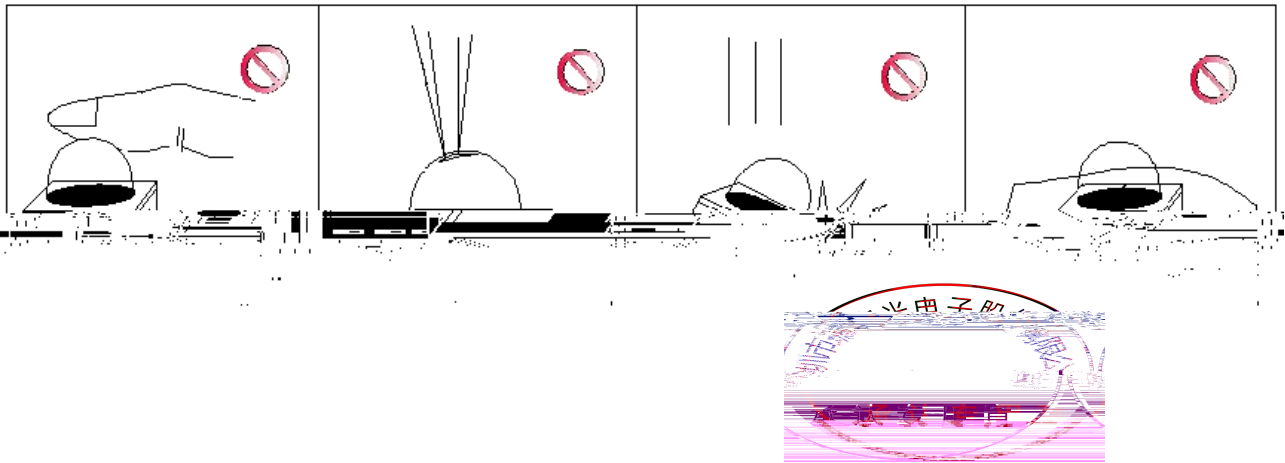



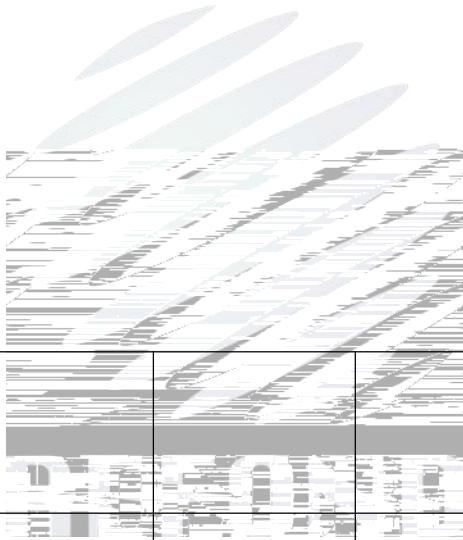

			士			

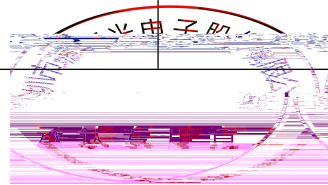

(7) ( ) ( ± ) °C

