



REFOND P/N

RF-W HV32DS-FH-F2

R&D

Mass Product

REFOND

Contents

1. Description	3
1.1 General Description	3
1.2 Features	3
1.3 Application	3
1.4 Product Selection Table	4
1.5 Package Dimension	4
1.6 Product Parameters	5
1.7 Bin Range Of Forward Voltage and Luminous Flux (IF=30mA)	BIN
(IF=30mA)	7
1.8 Typical optical characteristics curves	11
2. Packaging	15
2.1 Packaging Specification	15
2.1.1 Carrier Tape Dimension	
2.1.2 Reel Dimension	
2.1.3 Label Form Specification	
2.2 Moisture Resistant Packing	16
2.3 Cardboard Box	16
2.4 Reliability Test Items And Conditions	17
2.5 Criteria For Judging Damage	18
3. SMT Reflow Soldering Instructions SMT	19
3.1 SMT Reflow Soldering Instructions SMT	19
4. Handling Precautions	21
4.1 Handling Precautions	21

The White LED which was fabricated using a blue chip and the phosphor,

Package size: 2.8mm*3.5mm*0.7mm.

LED

2.8mmX3.5mmX0.7mm

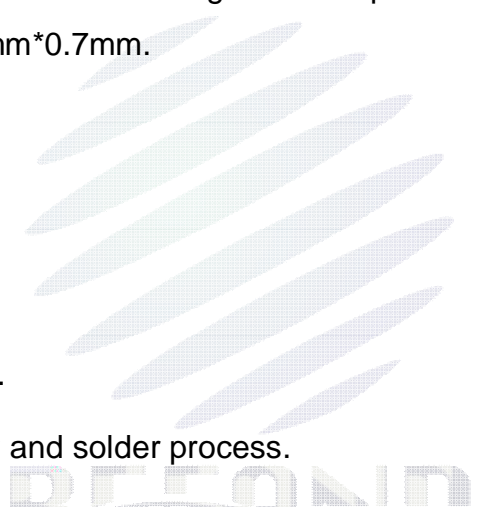

PLCC-2 Package.

Extremely wide viewing angle.

Suitable for all SMT assembly and solder process.

SMT

Available on tape and reel.

Moisture sensitivity level: Level 3.

Level 3

RoHS compliant. RoHS

Indoor lighting.

Bulb lighting.

General indoor applications.

Modle NO.	CCT	Center		
		code	x	y
RF-W2HV32DS-FH-F2	2700K	27M	0.4630	0.4200
RF-W3HV32DS-FH-F2	3000K	30M	0.4400	0.4030
RF-W4HV32DS-FH-F2	4000K	40M	0.3800	0.3800
RF-W5HV32DS-FH-F2	5000K	50M	0.3460	0.3590
RF-W57HV32DS-FH-F2	5700K	57M	0.3295	0.3426
RF-W60HV32DS-FH-F2	6000K	60M	0.3211	0.3353
RF-W6HV32DS-FH-F2	6500K	65M	0.3113	0.3346
RF-W68HV32DS-FH-F2	6800K	68M	0.3069	0.3306

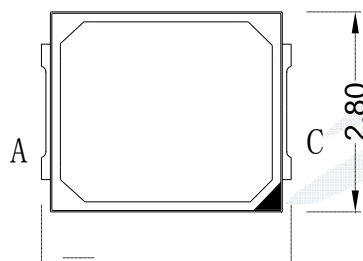

Fig.1-1 Top view

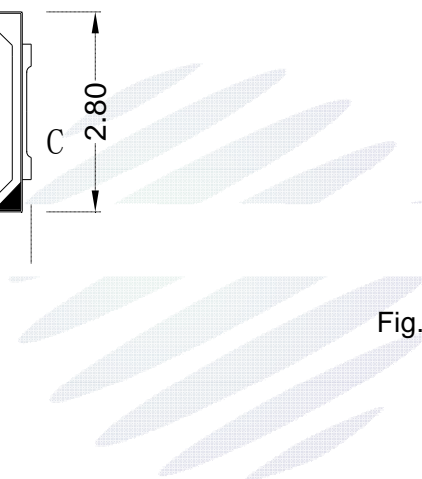

Fig.1-2 Side view



Fig.1-3 Bottom view

Fig.1-4 Polarity

Fig.1-5 Soldering patterns

Notes

1. All dimensions units are millimeters. mm
2. All dimensions tolerances are 0.05mm unless otherwise noted. ±0.05mm

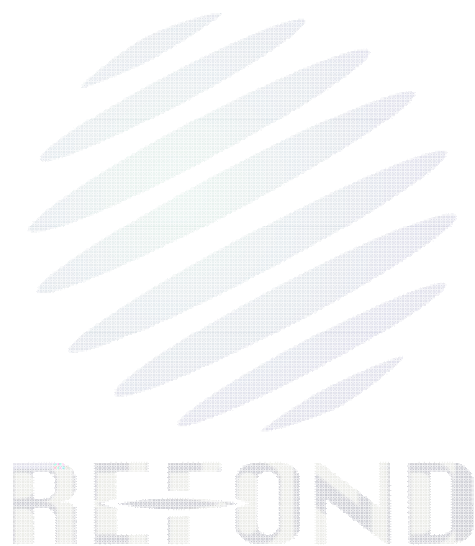

Table 1-2 Absolute Maximum Ratings at Ts=25°C

Parameter	Symbol	Rating	Units
Power Dissipation	P _D	1344	mW
Forward Current	I _F	35	mA
Peak Forward Current	I _{FP}	60	mA
Reverse Voltage	V _R	50	V
Operating Temperature	T _{OPR}	-40 ~ +100	
Storage Temperature	T _{STG}	-40 ~ +100	
Junction Temperature	T _J	125	

Notes

- 1/10 Duty cycle, 0.1ms pulse width. 0.1ms, 1/10.
- The above forward voltage measurement allowance tolerance is ±0.1V. ±0.1V.
- The above color coordinates measurement allowance tolerance is ±0.005. ±0.005.
- The above luminous intensity measurement allowance tolerance ±10%. ±10%.
- Care is to be taken that power dissipation does not exceed the absolute maximum rating of the product.
- All measurements were made under the standardized environment of Refond.
- When the LEDs are in operation the maximum current should be decided after measuring the package temperature junction temperature should not exceed the maximum rate. LED

Table 1-3

VF V	VM1	VM2	VM3	VM4
	35.2-36.0	36.0-36.8	36.8-37.6	37.6-38.4
Im RF-W2HV32DS-FH-F2	FC3	FC4		
	110-120	120-130		
Im RF-W3HV32DS-FH-F2	FC4	FC5		
	120-130	130-140		
Im RF-W4HV32DS-FH-F2 RF-W5HV32DS-FH-F2 RF-W57HV32DS-FH-F2 RF-W60HV32DS-FH-F2 RF-W6HV32DS-FH-F2	FC5	FC6		
	130-140	140-150		
RF-W68HV32DS-FH-F2	FC4	FC5	FC6	
	120-130	130-140	140-150	





E Chromaticity Diagram CIE

Table 1-4

27M	0.4796	0.4351	0.4610	0.4306	0.4472	0.4048	0.4643	0.4088				
30M	0.4567	0.4187	0.4361	0.4117	0.4247	0.3875	0.4429	0.3936				
40M	0.3944	0.3990	0.3723	0.3856	0.3667	0.3620	0.3867	0.3731				
50M	0.3565	0.3774	0.3371	0.3614	0.3364	0.3412	0.3534	0.3553				
57M	0.3357	0.3561	0.3218	0.3451	0.3232	0.3291	0.3370	0.3401				
60M	0.3273	0.3488	0.3134	0.3378	0.3148	0.3218	0.3286	0.3328				
65M	0.3175	0.3483	0.3034	0.3342	0.3055	0.3221	0.3184	0.3350				
68M	0.3131	0.3442	0.2992	0.3332	0.3006	0.3171	0.3144	0.3282				
27M-1	0.4407	0.3982	0.4503	0.4170	0.4541	0.4179	0.4472	0.4048	0.4559	0.4068	0.4526	0.4009
27M-2	0.4869	0.4412	0.4734	0.4381	0.4704	0.4329	0.4796	0.4351	0.4721	0.4220	0.4760	0.4229
27M-3	0.4594	0.4349	0.4734	0.4380	0.4704	0.4329	0.4610	0.4306	0.4541	0.4179	0.4503	0.4170
27M-4	0.4644	0.4036	0.4526	0.4009	0.4559	0.4069	0.4644	0.4088	0.4721	0.4220	0.4760	0.4229
30M-1	0.4175	0.3802	0.4259	0.3983	0.4305	0.3998	0.4247	0.3875	0.4337	0.3905	0.4308	0.3847
30M-2	0.4648	0.4268	0.4496	0.4217	0.4464	0.4153	0.4567	0.4187	0.4498	0.4062	0.4539	0.4069
30M-3	0.4343	0.4166	0.4496	0.4217	0.4464	0.4153	0.4361	0.4117	0.4305	0.3998	0.4259	0.3983
30M-4	0.4444	0.3892	0.4308	0.3847	0.4337	0.3905	0.4429	0.3936	0.4498	0.4062	0.4539	0.4069
40M-1	0.3609	0.3537	0.3643	0.3710	0.3695	0.3740	0.3667	0.3620	0.3770	0.3677	0.3755	0.3619
40M-2	0.4012	0.4071	0.3843	0.3975	0.3829	0.3921	0.3944	0.3990	0.3904	0.3858	0.3952	0.3885
40M-3	0.3677	0.3882	0.3843	0.3975	0.3829	0.3921	0.3723	0.3856	0.3696	0.3741	0.3643	0.3710
40M-4	0.3888	0.3696	0.3755	0.3619	0.3770	0.3677	0.3867	0.3731	0.3904	0.3858	0.3952	0.3885
50M-1	0.3325	0.3344	0.3328	0.3488	0.3368	0.3519	0.3364	0.3412	0.3450	0.3484	0.3446	0.3432
50M-2	0.3618	0.3860	0.3475	0.3745	0.3470	0.3696	0.3565	0.3774	0.3550	0.3659	0.3591	0.3693
50M-3	0.3329	0.3627	0.3475	0.3745	0.3470	0.3696	0.3371	0.3614	0.3368	0.3519	0.3328	0.3488
50M-4	0.3564	0.3518	0.3446	0.3432	0.3450	0.3484	0.3534	0.3553	0.3550	0.3660	0.3591	0.3693
57M-1	0.3193	0.3206	0.3182	0.3336	0.3225	0.3370	0.3232	0.3291	0.3296	0.3342	0.3299	0.3290
57M-2	0.3397	0.3642	0.3286	0.3554	0.3288	0.3507	0.3357	0.3561	0.3364	0.3477	0.3408	0.3512
57M-3	0.3171	0.3462	0.3286	0.3554	0.3288	0.3507	0.3218	0.3451	0.3225	0.3370	0.3182	0.3336
57M-4	0.3419	0.3385	0.3299	0.3290	0.3296	0.3342	0.3370	0.3401	0.3364	0.3477	0.3408	0.3512
60M-1	0.3109	0.3133	0.3098	0.3263	0.3141	0.3297	0.3148	0.3218	0.3212	0.3269	0.3214	0.3217
60M-2	0.3313	0.3569	0.3202	0.3481	0.3204							

60M-3	0.3087	0.3389	0.3202	0.3481	0.3204	0.3434	0.3134	0.3378	0.3141	0.3297	0.3098	0.3263
60M-4	0.3334	0.3313	0.3214	0.3217	0.3212	0.3269	0.3286	0.3328	0.3280	0.3404	0.3324	0.3439
65M-1	0.3017	0.3137	0.2994	0.3233	0.3044	0.3283	0.3055	0.3221	0.3120	0.3286	0.3123	0.3241
65M-2	0.3231	0.3584	0.3101	0.3457	0.3104	0.3412	0.3175	0.3483	0.3179	0.3416	0.3230	0.3465
65M-3	0.2970	0.3329	0.3101	0.3457	0.3104	0.3412	0.3034	0.3342	0.3044	0.3283	0.2994	0.3233
65M-4	0.3230	0.3346	0.3123	0.3241	0.3120	0.3286	0.3184	0.3350	0.3179	0.3416	0.3230	0.3465
68M-1	0.2967	0.3086	0.3072	0.3170	0.3070	0.3223	0.3006	0.3171	0.2999	0.3250	0.2956	0.3217
68M-2	0.3171	0.3523	0.3060	0.3434	0.3062	0.3387	0.3131	0.3442	0.3138	0.3358	0.3182	0.3393
68M-3	0.2945	0.3342	0.3060	0.3434	0.3062	0.3387	0.2992	0.3332	0.2999	0.3250	0.2956	0.3217
68M-4	0.3193	0.3266	0.3072	0.3170	0.3070	0.3223	0.3144	0.3282	0.3138	0.3358	0.3182	0.3393

Table 1-5

CCT	CIE Kit	Reel 1	Reel 2
2700K	Kit 1	27M	27M
	Kit 2	27M-1	27M-2
	Kit 3	27M-3	27M-4
3000K	Kit 1	30M	30M
	Kit 2	30M-1	30M-2
	Kit 3	30M-3	30M-4
4000K	Kit 1	40M	40M
	Kit 2	40M-1	40M-2
	Kit 3	40M-3	40M-4
5000K	Kit 1	50M	50M
	Kit 2	50M-1	50M-2
	Kit 3	50M-3	50M-4
5700K	Kit 1	57M	57M
	Kit 2	57M-1	57M-2
	Kit 3	57M-3	57M-4
6000K	Kit 1	60M	60M
	Kit 2	60M-1	60M-2
	Kit 3	60M-3	60M-4
6500K	Kit 1	65M	65M
	Kit 2	65M-1	65M-2
	Kit 3	65M-3	65M-4
6800K	Kit 1	68M	68M
	Kit 2	68M-1	68M-2
	Kit 3	68M-3	68M-4

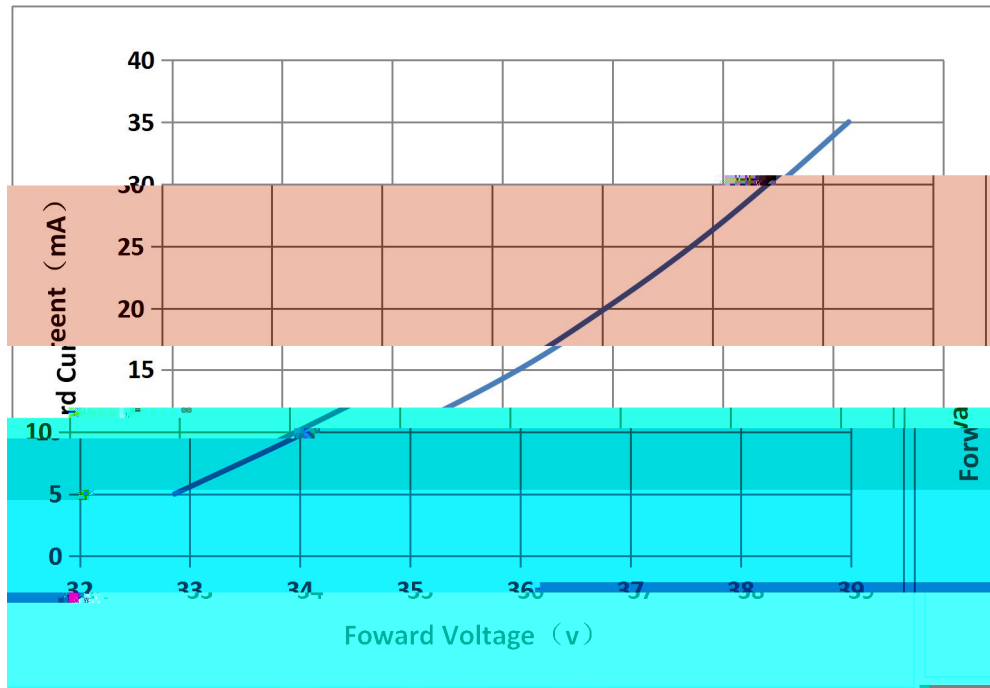

Fig 1-7 Forward Voltage Vs. Forward Current

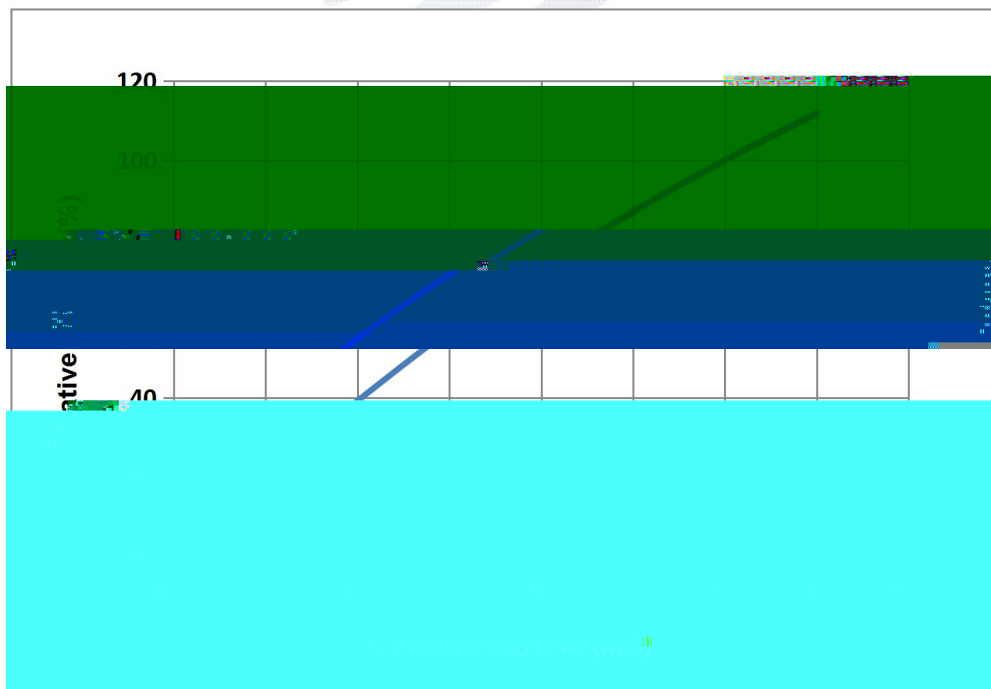

Fig 1-8 Forward Current Vs. Relative Intensity

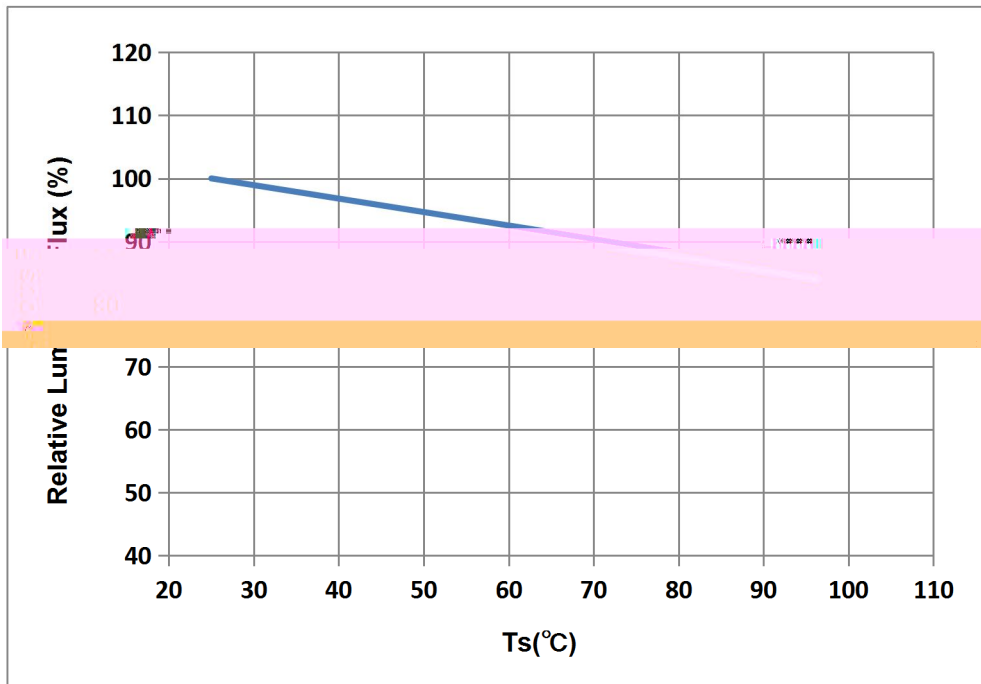

Fig 1-9 Solder Temperature Vs Relative Intensity

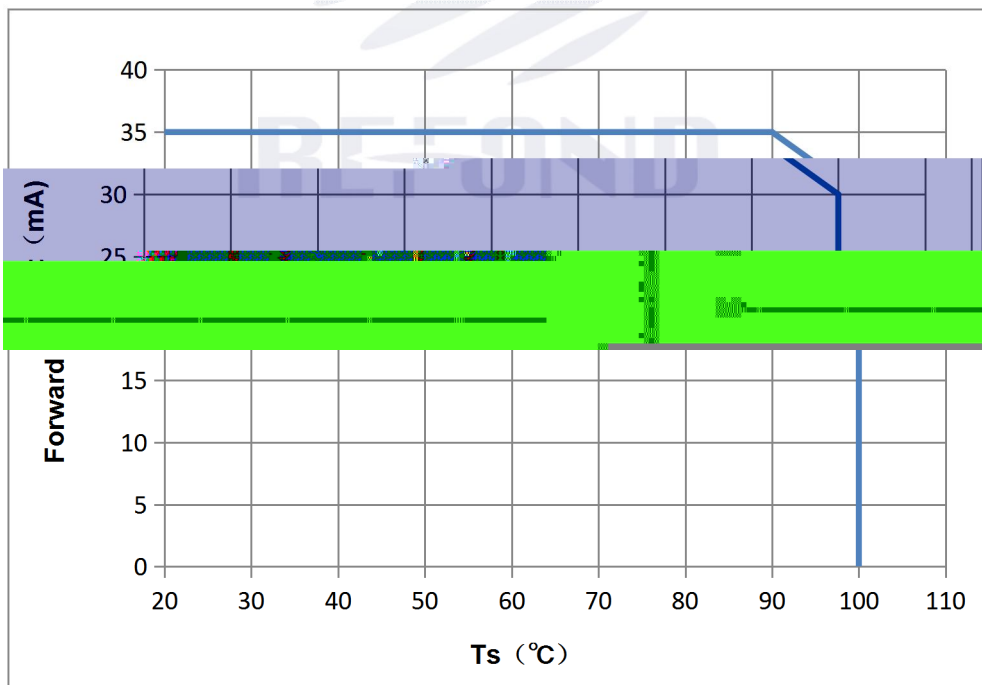

Fig 1-10 Solder Temperature Vs Forward Current

Tj 125

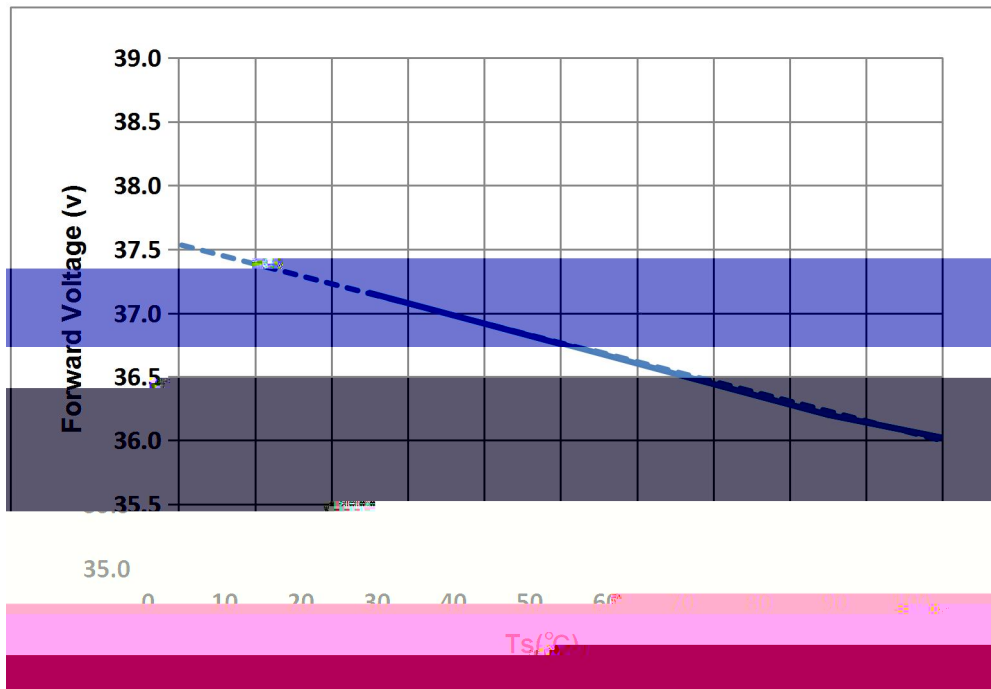

Fig 1-11 Forward Voltage Vs Solder Temperature

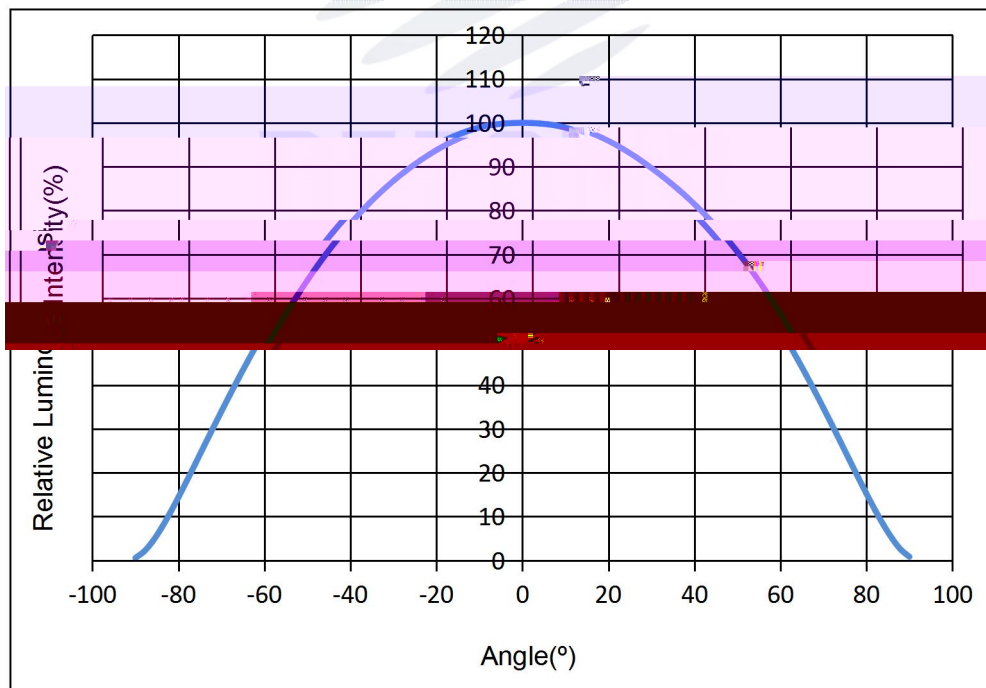

Fig 1-12 Radiation diagram

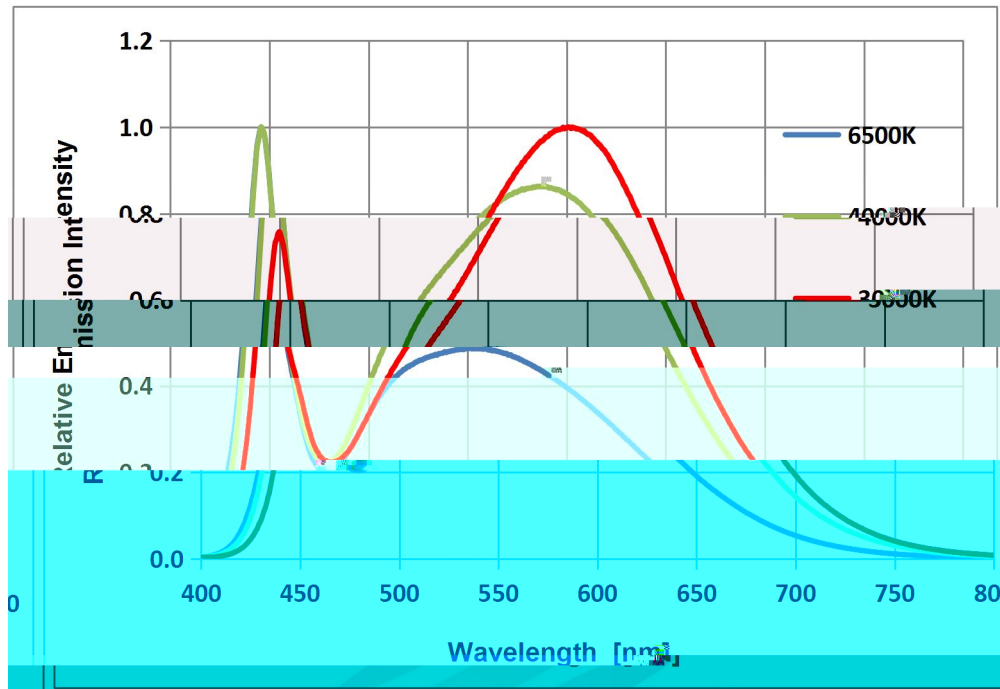

Fig 1-13 Spectrum Distribution

REFOND



瑞豐光電



2.1.3 Label Form Specification

Table 2-2 Title

PART NO.

Fig 2-3 Title



Fig.2- Title

Fig.2- Title

Table 2-3.T

Test Items	Ref. Standard	Test Co	Time	Quantity
------------	---------------	---------	------	----------



Table 2-4 Title

Test Items	Symbol	Test Condition	Criteria For Judgement	
			Min.	Max.
Forward Voltage	V_F	$I_F=30mA$	-	(U.S.L*)x1.1
Reverse Current	I_R	$V_R = 50V$	-	(U.S.L*)x2.0
Luminous Flux		$I_F=30mA$	(L.S.L*)x0.7	-

Notes

1.U.S.L: Upper standard level

L.S.L: Lower standard level

2. The above reliability tests is based on the verification of a single/strip LED of Refond's existing experimental platform, the reliability experiment was taken under good heat dissipation conditions. when customers applies the LED to the series and parallel circuit, should take consideration of all the factors such as the current, voltage distribution, heat dissipation and others.

/ LED

LED

3.The technical information shown in the data sheets are limited to the typical characteristics and circuit examples of the referenced products. It does not constitute the warranting of industrial property nor the granting of any license.

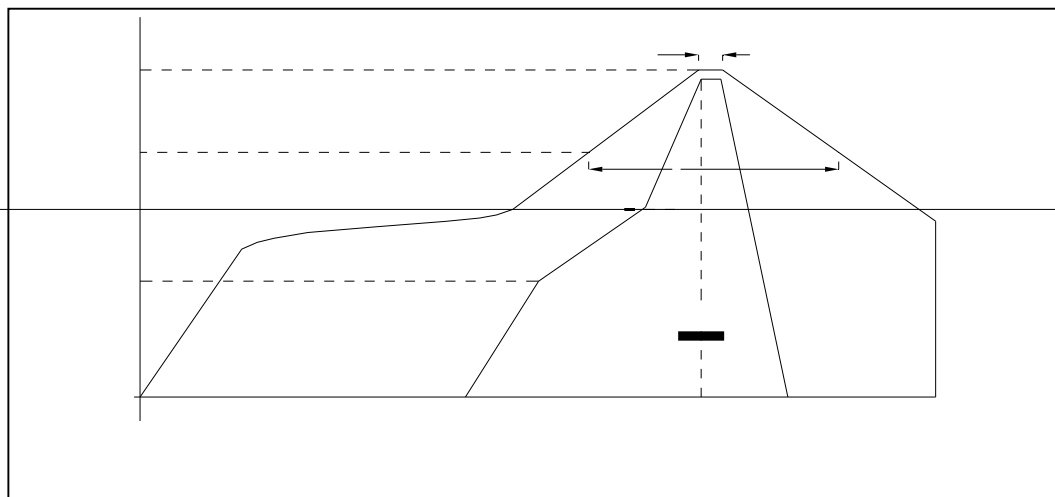

Fig.3-1Title

Table 3-1Title

Average temperature rise speed	T_{smax}	T_P	3 °C/	Max 3 °C/ s
Preheating: minimum temperature	(T _{smin})		150 °C	
Preheating: Max temperature	(T _{smax})		200 °C	
Preheating: Time	T _{smin}	T _{smax}	60 - 120	60s-120s
Time limited to maintain high temperature: the temperature			(T _L)	217 °C
Time limited to maintain high temperature: The Time			(t _L)	60 Max 60s
Peak /Classification of temperature:	/	(T _P)	260 °C	
Time limit classification of peak temperature time			t _p	10 Max 10s
Hold time within 5 °C with the actual peak temperature (TP)			(T _P)	30 Max 30s
5 °C				
Cooling speed			6 °C/	Max 6 °C/ s
Needed time from 25 °C to T _p	25 °C			
			8	Max 8 minutes

Notes

(1)Reflow soldering should not be done more than two times. In the case of more than 24 hours passed soldering after first, LEDs will be damaged.

24

LED

(2)When soldering , do not put stress on the LEDs during heating.

3.1.1 Soldering Iron

(1) When hand soldering, keep the temperature of iron below



(3) Do not apply mechanical force or excess vibration during the cooling process to normal temperature after soldering. Do not rapidly cool device after soldering.

(1) LED operating environment and sulfur element composition cannot be over 100PPM in the LED mating usage material. This is provided for informational purposes only and is not a warranty or endorsement. LED LED 100PPM.

(2) In order to prevent external material from getting into the inside of LED, which may cause the malfunction of LED, the single content of Bromine element is required to be less than 900PPM, the single content of Chlorine element is required to be less than 900PPM, the total content of Bromine element and Chlorine element in the external materials of the application products is required to be less than 1500PPM. This is provided for informational purposes only and is not a warranty or endorsement. LED LED 900PPM 900PPM 1500PPM.

(3) VOCs (Volatile organic compounds) emitted from materials used in the construction of fixtures can penetrate silicone encapsulants of LEDs and discolor when exposed to heat and photonic energy. The result can be a significant loss of light output from the fixture. Knowledge of the properties of the materials selected to be used in the construction of fixtures can help prevent these issues. Refond advises against the use of any chemicals or materials that have been found or are suspected to have an adverse affect on device performance or reliability. To verify compatibility, Refond recommends that all chemicals and materials be tested in the specific application and environment for which they are intended to be used. Attaching LEDs, do not use adhesives that outgas organic vapor. LED

LED

LED

LED

(4) Handle the component along the side surface by using forceps or appropriate tools; do not directly touch or Handle the silicone lens surface, it may damage the internal circuitry.

Fig 4-1 Title

(5) In designing a circuit, the current through each LED can not exceed the absolute maximum rating specified for each LED. In the mean while, resistors for protection should be applied, otherwise slight voltage shift will cause big current change, burn out may happen. The driving circuit must be designed to allow forward voltage only when it is ON or OFF. If the reverse voltage is applied to LED, migration can be generated resulting in LED damage.

LED

LED

(6) Thermal Design is paramount importance because heat generation may result in the Characteristics decline, such as brightness decreased, Color change and so on. Please consider the heat generation of the LEDs when making the system design.LED

LED

(7) Compared to standard encapsulants, silicone is generally softer, and the surface is more likely to attract dust requiring special care during processing. In cases where a minimal level of dirt and dust particles cannot be guaranteed, a suitable cleaning solution must be applied to the surface after the soldering of components. Refond suggests using isopropyl alcohol for cleaning.

package or resin. Ultrasonic cleaning is not recommended. Ultrasonic cleaning may cause damage to the LED.

LED

Table 4-1 Storage

Conditions		Temperature	Humidity	Time
Storage	Before Opening Aluminum Bag	30	75%	Within 1 Year From Date
	After Opening Aluminum Bag	30	60%	24hours 24
Baking		60±5	-	24hours 24

(8) If the moisture absorbent material silica gel has faded away or the LEDs have exceeded the storage time baking treatment should be performed after unpacking and based on the following condition

60±5 24

If the package is flatulence or damaged, please notify the sales staff to assist.

(9) Similar to most Solid state devices; LEDs are sensitive to Electro-Static Discharge (ESD) and Electrical Over Stress (EOS).

LED

(10) Other points for attention, please refer to our relevant information.



www.refond.com

REFOND

Declare

This specification is written both in English and in Chinese and the latter is formal.