

# SPECIFICATION

REFOND P/N

RF-W\*HV32DS-FF-E3

REFOND  
Mass Product

# Contents

1. Description	3
1.1 General Description	3
1.2 Features	3
1.3 Application	3
1.4 Product Selection Table	4
1.5 Package Dimension	4
1.6 Product Parameters	5
1.7 Bin Range Of Forward Voltage and Luminous Flux (IF=20mA)	BIN
(IF=20mA)	7
1.8 Typical optical characteristics curves	10
2. Packaging	14
2.1 Packaging Specification	14
2.1.1 Carrier Tape Dimension	14
2.1.2 Reel Dimension	14
2.1.3 Label Form Specification	15
2.2 Moisture Resistant Packing	15
2.3 Cardboard Box	15
2.4 Reliability Test Items And Conditions	16
2.5 Criteria For Judging Damage	17
3. SMT Reflow Soldering Instructions SMT	18
3.1 SMT Reflow Soldering Instructions SMT	18
4. Handling Precautions	20
4.1 Handling Precautions	20

## 1. Description

### 1.1

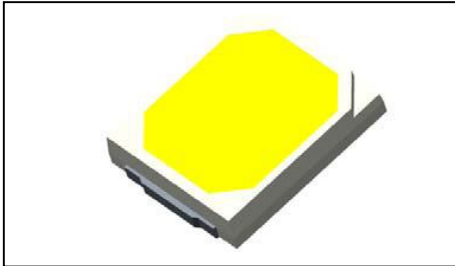

The White LED which was fabricated using a blue chip and the phosphor

LED

2.8mmX3.5mmX0.7mm

### 1.2 Features

PLCC-2 Package.

Extremely wide viewing angle.

Suitable for all SMT assembly and solder process.

SMT

Available on tape and reel.

Moisture sensitivity level: Level 3. Level 3

RoHS compliant. RoHS

### 1.3 Application

Indoor lighting.

Bulb lighting.

General indoor applications.

## 1.4 Product Selection Table

Modle NO.	CCT	Center		
		code	x	y
RF-W2HV32DS-FF-E3	2700K	27M	0.4630	0.4200
RF-W3HV32DS-FF-E3	3000K	30M	0.4400	0.4030
RF-W4HV32DS-FF-E3	4000K	40M	0.3800	0.3800
RF-W5HV32DS-FF-E3	5000K	50M	0.3460	0.3590
RF-W57HV32DS-FF-E3	5700K	57M	0.3295	0.3426
RF-W65HV32DS-FF-E3	6500K	65M	0.3154	0.3407

## 1.5 Package Dimension

Fig.1-1 Top view

Fig.1-2 Side view



Fig.1-3 Bottom view

Fig.1-4 Polarity

Fig.1-5 Soldering patterns

### Notes

All dimensions units are

## 1.6 Product Parameters

Table 1-1 Electrical / Optical Characteristics at Ts=25°C

Item	Code	Symbol	test condition	RF-Value			unit
				Min.	Max.	Typ.	
Forward Voltage	Rank VG1	$V_F$	$I_F=20mA$	52.4	53.2	54.0	V
	Rank VG2			53.2	54.0		V
	Rank VG3			54.0	54.8		V
	Rank VG4			54.8	55.6		V
RF-W2HV32DS-FF-E3	Rank FC4		$I_F=20mA$	120	130	142	lm
	Rank FC5			130	140		lm
	Rank FC6			140	150		lm
RF-W3HV32DS-FF-E3	Rank FC5		$I_F=20mA$	130	140	150	lm
	Rank FC6			140	150		lm
	Rank FC7			150	160		lm
RF-W4HV32DS-FF-E3	Rank FC6		$I_F=20mA$	140	150	160	lm
	Rank FC7			150	160		lm
	Rank FC8			160	170		lm
RF-W5HV32DS-FF-E3	Rank FC6		$I_F=20mA$	140	150	160	lm
	Rank FC7			150	160		lm
	Rank FC8			160	170		lm
RF-W57HV32DS-FF-E3	Rank FC6		$I_F=20mA$	140	150	160	lm
	Rank FC7			150	160		lm
	Rank FC8			160	170		lm
RF-W65HV32DS-FF-E3	Rank FC6		$I_F=20mA$	140	150	158	lm
	Rank FC7			150	160		lm
	Rank FC8			160	170		lm
Reverse Current		$I_R$	$V_R=50V$	---	10	---	uA
Viewing Angle		$2\theta/2$	$I_F=20mA$	---	---	120	Deg
Color Rendering Index		CRI		80	---	82	---
Thermal resistance		$R_{THJ-S}$		---	---	20	/W



## 1.7 Bin Range Of Forward Voltage and Luminous Flux (IF=20mA)

### BIN (IF=20mA)

Table 1-3

VF V	VG1	VG2	VG3	VG4
		52.4-53.2	53.2-54.0	54.0-54.8
Im RF-W2HV32DS-FF-E3	FC4 120-130	FC5 130-140	FC6 140-150	
Im RF-W3HV32DS-FF-E3	FC5 130-140	FC6 140-150	FC7 150-160	
Im RF-W4HV32DS-FF-E3	FC6 140-150	FC7 150-160	FC8 160-170	
Im RF-W5HV32DS-FF-E3	FC6 140-150	FC7 150-160	FC8 160-170	
Im RF-W57HV32DS-FF-E3	FC6 140-150	FC7 150-160	FC8 160-170	
Im RF-W65HV32DS-FF-E3	FC6 140-150	FC7 150-160	FC8 160-170	

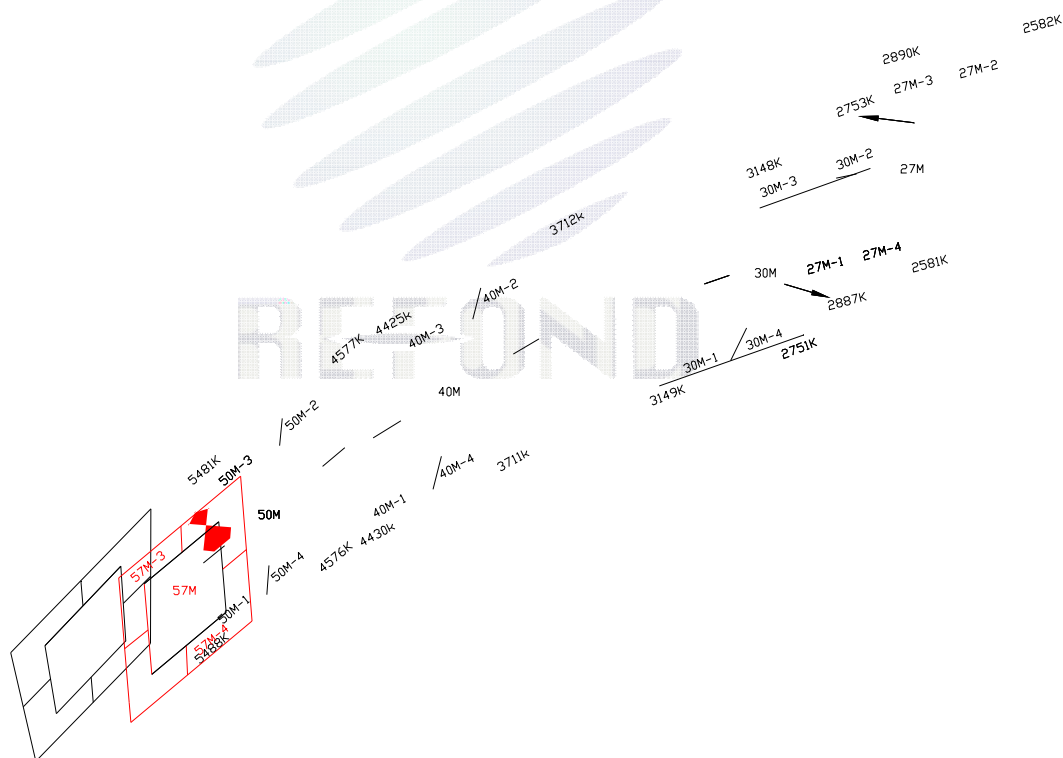

Fig 1-6 The C.I.E Chromaticity Diagram CIE

Table 1-4

**ERP 5-step**

BIN CODE	X1	Y1	X2	Y2	X3	Y3	X4	Y4
27M	0.4796	0.4351	0.4610	0.4306	0.4472	0.4048	0.4643	0.4088
30M	0.4567	0.4187	0.4361	0.4117	0.4247	0.3875	0.4429	0.3936
40M	0.3944	0.3990	0.3723	0.3856	0.3667	0.3620	0.3867	0.3731
50M	0.3565	0.3774	0.3371	0.3614	0.3364	0.3412	0.3534	0.3553
57M	0.3357	0.3561	0.3218	0.3451	0.3232	0.3291	0.3370	0.3401
65M	0.3175	0.3483	0.3034	0.3342	0.3055	0.3221	0.3184	0.3350

**ERP 7-step**

BIN CODE	X1	Y1	X2	Y2	X3	Y3	X4	Y4	X5	Y5	X6	Y6
27M-1	0.4407	0.3982	0.4503	0.4170	0.4541	0.4179	0.4472	0.4048	0.4559	0.4068	0.4526	0.4009
27M-2	0.4869	0.4412	0.4734	0.4381	0.4704	0.4329	0.4796	0.4351	0.4721	0.4220	0.4760	0.422





## Kitting Principles BIN

Table 1-5

CIE Kitting			
CCT	CIE Kit	Reel 1	Reel 2
2700K	Kit 1	27M	27M
	Kit 2	27M-1	27M-2
	Kit 3	27M-3	27M-4
3000K	Kit 1	30M	30M
	Kit 2	30M-1	30M-2
	Kit 3	30M-3	30M-4
4000K	Kit 1	40M	40M
	Kit 2	40M-1	40M-2
	Kit 3	40M-3	40M-4
5000K	Kit 1	50M	50M
	Kit 2	50M-1	50M-2
	Kit 3	50M-3	50M-4
5700K	Kit 1	57M	57M
	Kit 2	57M-1	57M-2
	Kit 3	57M-3	57M-4
6500K	Kit 1	65M	65M
	Kit 2	65M-1	65M-2
	Kit 3	65M-3	65M-4



## 1.8 Typical optical characteristics curves

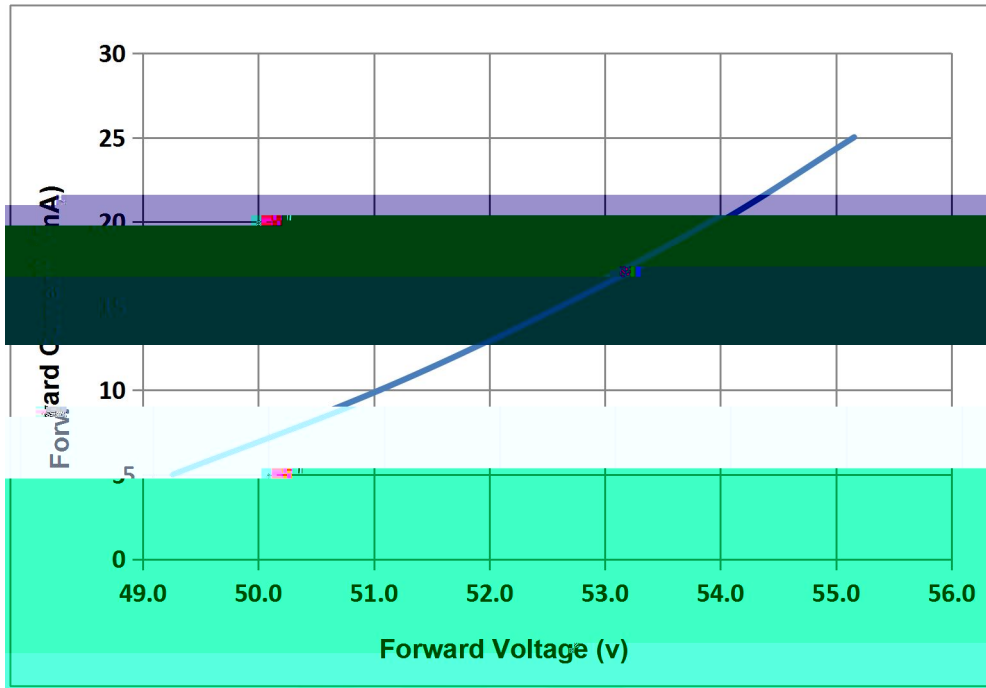

Fig 1-7 Forward Voltage Vs. Forward Current

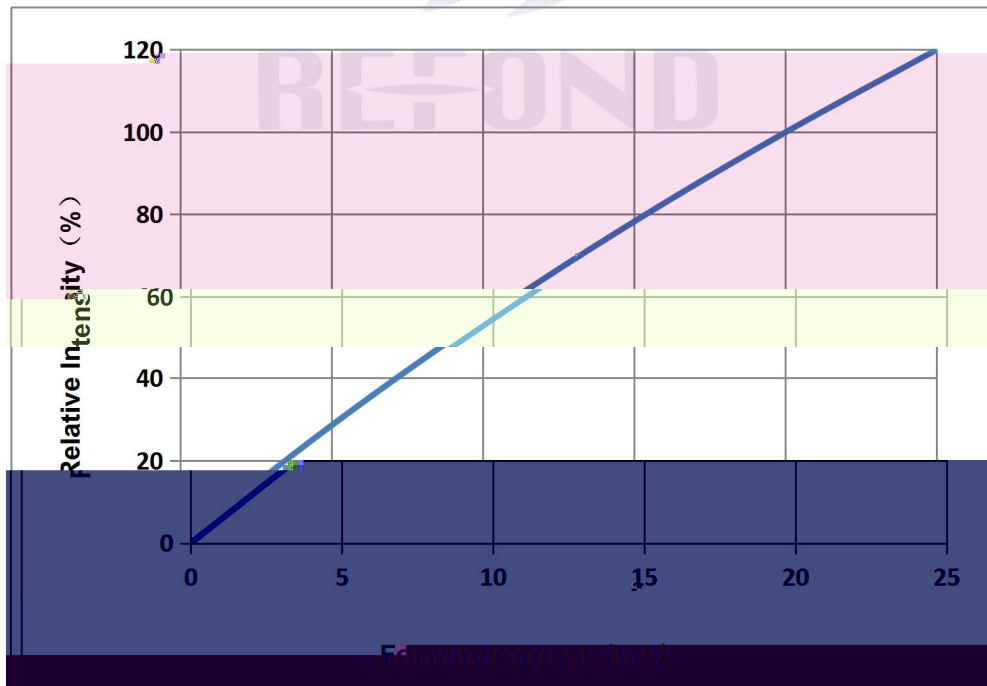

Fig 1-8 Forward Current Vs. Relative Intensity



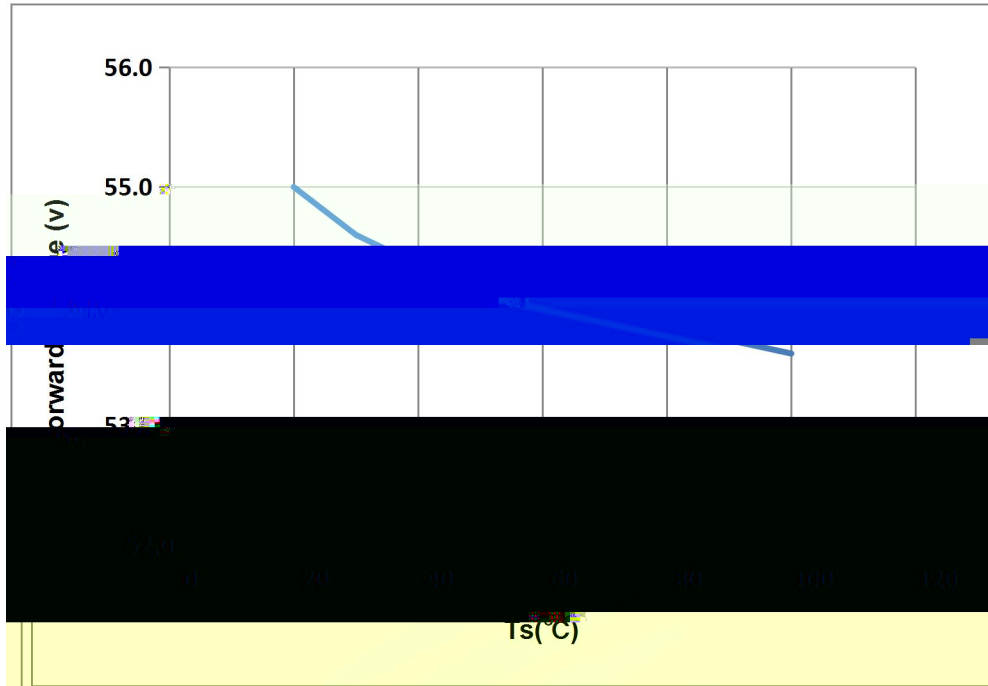

Fig 1-11 Forward Voltage Vs Solder Temperature

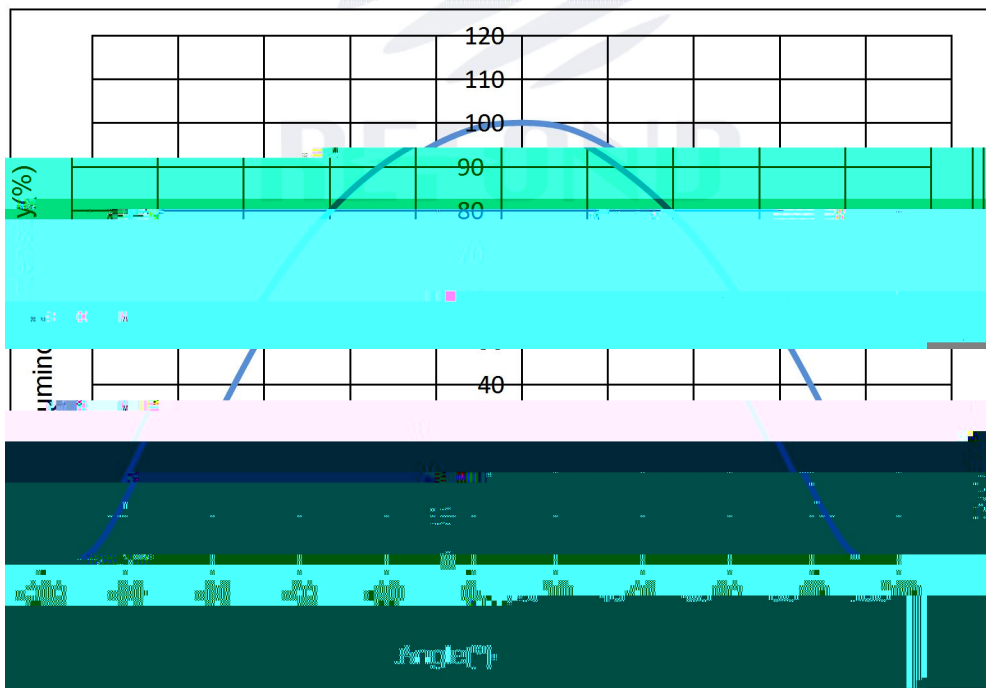

Fig 1-12 Radiation diagram

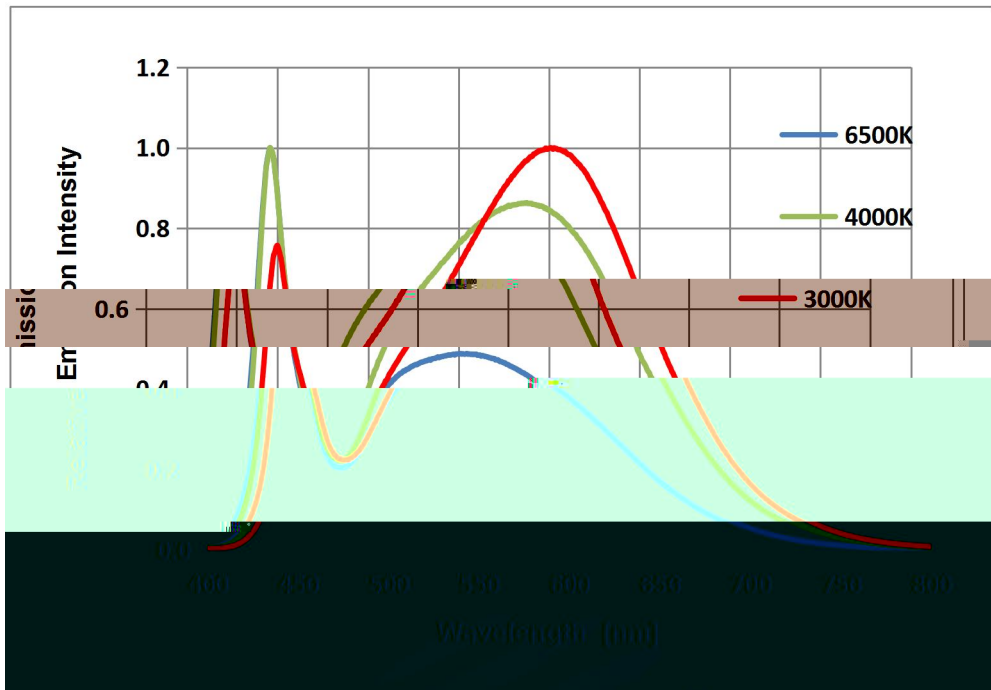

Fig 1-13 Spectrum Distribution

REFOND

## 2. Packaging

### 2.1 Packaging Specification

Package: 12000pcs/reel or 4000pcs/reel.

12000pcs      4000pcs

#### 2.1.1 Carrier Tape Dimension

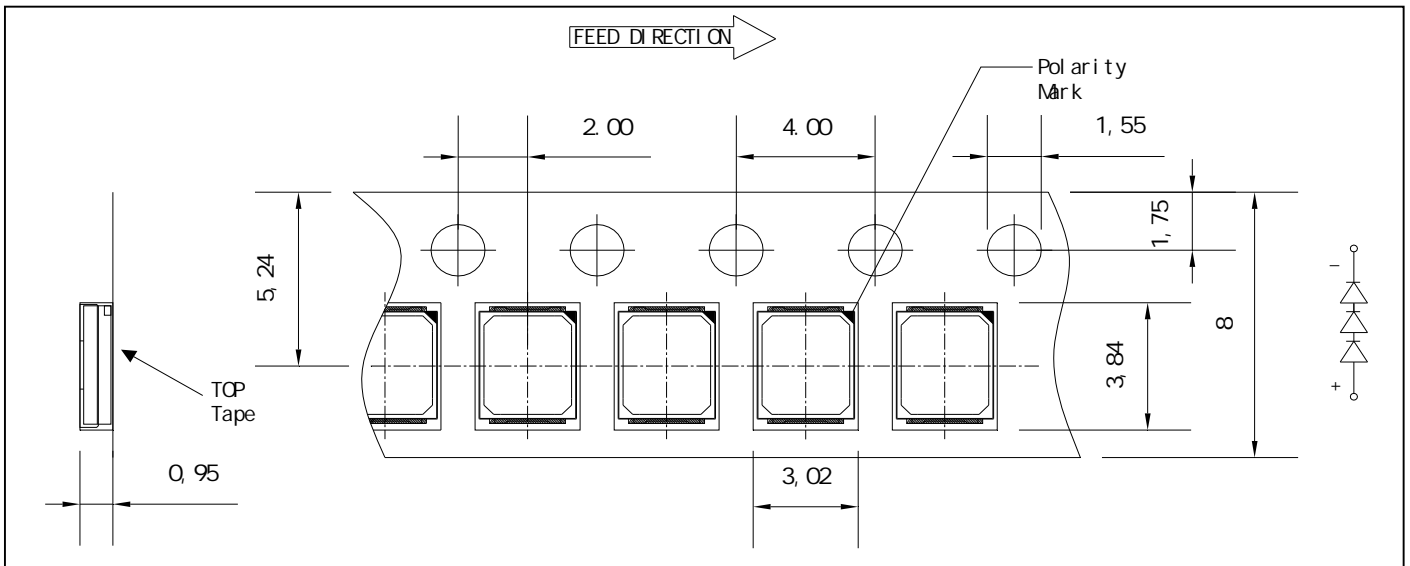

Fig.2-1 Carrier Tape Dimension

#### 2.1.2 Reel Dimension

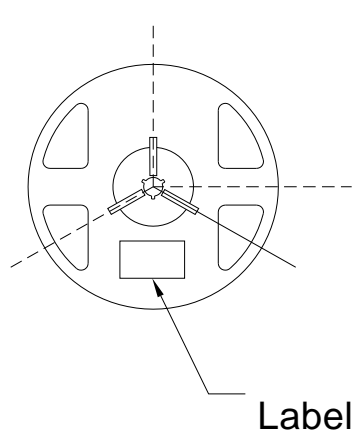
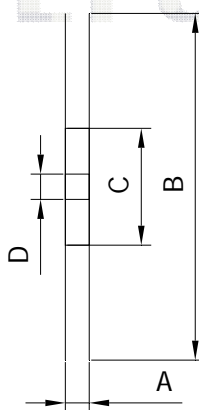

Fig.2-2 Title



	12000pcs	4000pcs
A	12.2 0.3mm	11.75 0.3mm
B	290 2mm	177.8 0.2mm
C	79.6 0.2mm	58.5 0.2mm
D	14.2 0.2mm	13.5 0.2mm

#### Notes

The tolerances unless mentioned  $\pm 0.1$ mm. Unit : mm

$\pm 0.1$

Form Specification

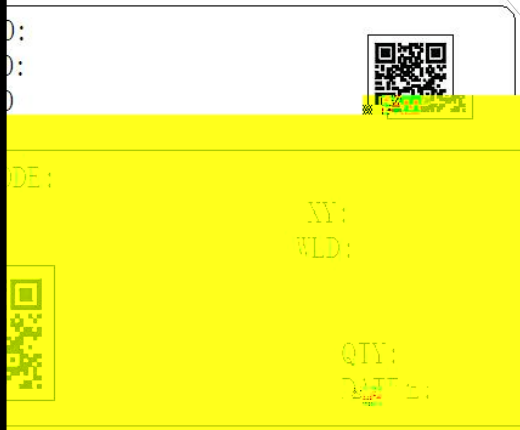

Fig 2-3 Title

PART NO.	Part Number
SPEC NO.	Spec Number
LOT NO.	Lot Number
BIN CODE	Bin Code
	Luminous flux
XY	Chromaticity Bin
V <sub>F</sub>	Forward Voltage
WLD	Wavelength
QTY	Packing Quantity
DATE	Made Date

Moisture Resistant Packing

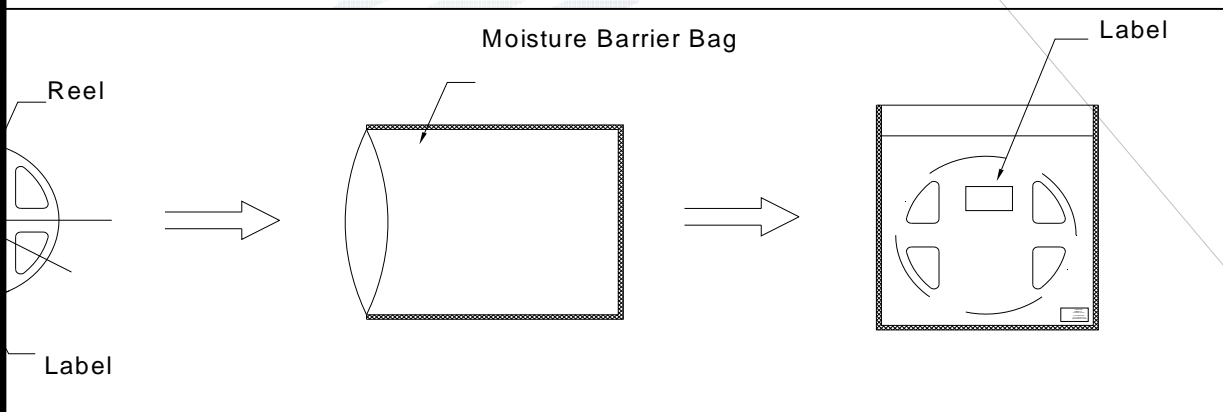

Fig.2-4Title

Card Box

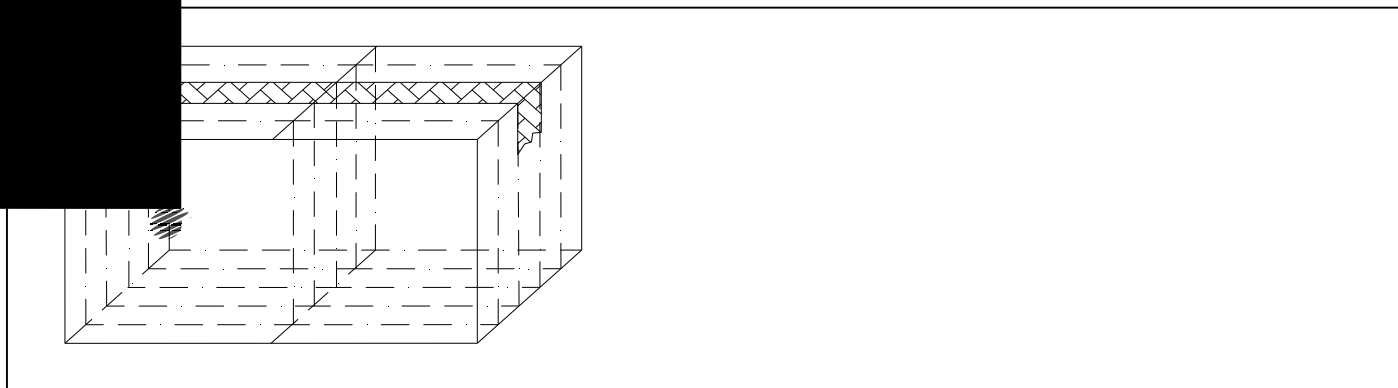

Fig.2-5Title

## 2.4 Reliability Test Items And Conditions

Table 2-3 Title

TestItems	Ref.Standard	Test Condition	Time	Quantity	Ac/Re /
Reflow	JESD22-B106	Temp:260 max T=10 sec	2times	10pcs	0/1
Thermal Shock	JEITAED-4701 300307	-40 15min 10s 100 15min	200cycles	10pcs	0/1
High Temperature Storage	JEITAED-4701 200 201	Temp:100	1000hrs	10pcs	0/1
Low Temperature Storage	JEITA ED-4701 200 202	Temp:-40	1000hrs	10pcs	0/1
Life Test	JESD22-A108	Ta=25 I <sub>F</sub> =20mA	1000hrs	10pcs	0/1
High Temperature High Humidity Life Test	JESD22-A101	60 / 90%RH I <sub>F</sub> =20mA	1000hrs	10pcs	0/1
Temperature Humidity Storage	JEITA ED-4701 100 103	T <sub>A</sub> =85 R <sub>H</sub> =85%	1000hrs	10pcs	0/1
Sulfur test	/	80 4H 0.6	4hrs	10pcs	0/1



## 2.5 Criteria For Judging Damage

Table 2-4 Title

Test Items	Symbol	Test Condition	Criteria For Judgement	
			Min.	Max.
Forward Voltage	$V_F$	$I_F=20mA$	-	$(U.S.L^*) \times 1.1$
Reverse Current	$I_R$	$V_R = 50V$	-	$(U.S.L^*) \times 2.0$
Luminous Flux		$I_F=20mA$	$(L.S.L^*) \times 0.7$	-

### Notes

1.U.S.L: Upper standard level

L.S.L: Lower standard level

2. The above reliability tests is based on the verification of a single/strip LED of Refond's existing experimental platform, the reliability experiment was taken under good heat dissipation conditions. when customers applies the LED to the series and parallel circuit, should take consideration of all the factors such as the current, voltage distribution, heat dissipation and others.

/ LED

LED

3.The technical information shown in the data sheets are limited to the typical characteristics and circuit examples of the referenced products. It does not constitute the warranting of industrial property nor the granting of any license.

### 3. SMT Reflow Soldering Instructions SMT

#### 3.1 SMT Reflow Soldering Instructions SMT

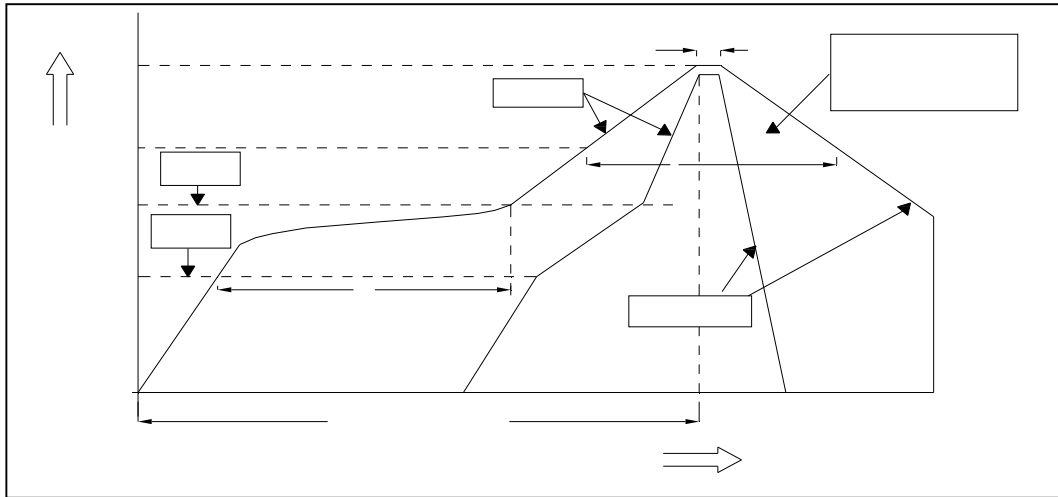

Fig.3-1Title

Table 3-1Title

Average temperature rise speed	$T_{smx}$ $T_P$	3 °C/ Max 3 °C/ s
Preheating: minimum temperature	( $T_{smin}$ )	150 °C
Preheating: Max temperature	( $T_{smx}$ )	200 °C
Preheating: Time	$T_{smin}$ $T_{smx}$	60 - 120 60s-120s
Time limited to maintain high temperature: the temperature	( $T_L$ )	217 °C
Time limited to maintain high temperature: The Time	( $t_l$ )	60 Max 60s
Peak /Classification of temperature:	( $T_P$ )	260 °C
Time limit classification of peak temperature time	$t_p$	10 Max 10s
Hold time within 5 °C with the actual peak temperature (TP)	( $T_P$ )	30 Max 30s
5 °C		
Cooling speed		6 °C/ Max 6 °C/ s
Needed time from 25 °C to $T_p$ 25 °C		8 Max 8 minutes

## Notes

(1) Reflow soldering should not be done more than two times. In the case of more than 24 hours passed soldering after first, LEDs will be damaged.

(2) When soldering, do not put stress on the LEDs during heating.

### 3.1.1 Soldering Iron

(1) When hand soldering, keep the temperature of iron below less 300 less than 3 seconds

(2) The hand solder should be done only one time.

### 3.1.2 Repairing

Repair should not be done after the LEDs have been soldered. When repairing is unavoidable, a double-head soldering iron should be used (as below figure). It should be confirmed in advance whether the characteristics of LEDs will or will not be damaged by repairing.

LED

### 3.1.3 Cautions

(1) The encapsulated material of the LEDs is silicone. Therefore the LEDs have a soft surface on the top of package. The pressure to the top surface will be influence to the reliability of the LEDs. Precautions should be taken to avoid the strong pressure on the encapsulated part. So when use the picking up nozzle, the pressure on the silicone resin should be proper. LED

(2) Components should not be mounted on warped (non coplanar) portion of PCB. After soldering, do not warp the circuit board. LED

(3) Do not apply mechanical force or excess vibration during the cooling process to normal temperature after soldering. Do not rapidly cool device after soldering.

## 4. Handling Precautions

### 4.1 Handling Precautions

(1) LED operating environment and sulfur element composition cannot be over 100PPM in the LED mating usage material. This is provided for informational purposes only and is not a warranty or endorsement.LED

(2) In order to prevent external material from getting into the inside of LED, which may cause the malfunction of LED, the single content of Bromine element is required to be less than 900PPM,the single content of Chlorine element is required to be less than 900PPM,the total content of Bromine element and Chlorine element in the external materials of the application products is required to be less than 1500PPM. This is provided for informational purposes only and is not a warranty or endorsement.

(3) VOCs (Volatile organic compounds) emitted from materials used in the construction of fixtures can penetrate silicone encapsulants of LEDs and discolor when exposed to heat and photonic energy. The result can be a significant loss of light output from the fixture. Knowledge of the properties of the materials selected to be used in the construction of fixtures can help prevent these issues. Refond advises against the use of any chemicals or materials that have been found or are suspected to have an adverse affect on device performance or reliability. To verify compatibility, Refond recommends that all chemicals and materials be tested in the specific application and environment for which they are intended to be used. Attaching LEDs, do not use adhesives that outgas organic vapor.



package or resin. Ultrasonic cleaning is not recommended. Ultrasonic cleaning may cause damage to the LED.

Table 4-1Storage

Conditions		Temperature	Humidity	Time
Storage	Before Opening Aluminum Bag	30	75%	Within 1 Year From Date
	After Opening Aluminum Bag	30	60%	24hours 24
Baking		60 5	-	24hours 24

(8) If the moisture absorbent material silica gel has faded away or the LEDs have exceeded the storage time baking treatment should be performed after unpacking and based on the following condition 60 5 for above 24 hours.

If the package is flatulence or damaged, please notify the sales staff to assist.

(9) Similar to most Solid state devices; LEDs are sensitive to Electro-Static Discharge (ESD) and Electrical Over Stress (EOS).

(10) Other points for attention, please refer to our relevant information.





www.refond.com



Declare

This specification is written both in English and in Chinese and the latter is formal.