

SPECIFICATION

REFOND P/N

RF-W*HP32DS-FH-I3

R&D
Mass Product
REFOND



1. Description

1.1

The White LED which was fabricated using a blue chip and yellow phosphor



1.4 Package Dimension

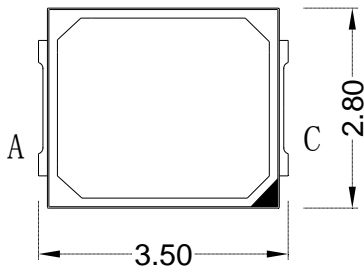

Fig.1-1 Top view

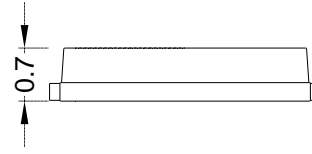

Fig.1-2 Side view

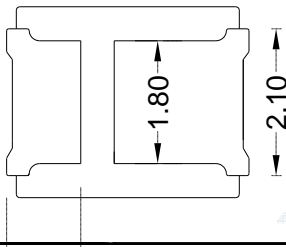
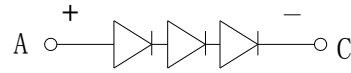

Fig.1-3 Bottom view



A: anode
C: cathode

Fig.1-4 Polarity

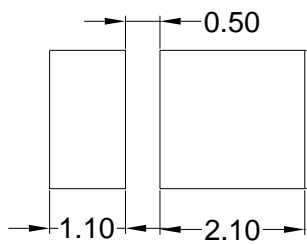

Fig.1-5 Soldering patterns

Notes

1. All dimensions units are millimeters.
2. All dimensions tolerances are $\pm 0.05\text{mm}$ unless otherwise noted.

± 0.05

1.5 Product Parameters

Table 1-1 Electrical / Optical Characteristics at Ts=25°C

Item	Code	Symbol	Test Condition	RF-Value			Unit
				Min.	Max.	Typ.	
Forward Voltage	Rank Y0	V_F	$I_F = 100\text{mA}$	8.6	9.0	8.9	V
	Rank Z0			9.0	9.4		V
RF-W57HP32DS-FH-I3	Rank FC6		$I_F = 100\text{mA}$	140	150	155	lm
	Rank FC7			150	160		lm
	Rank FC8			160	170		lm
RF-W6HP32DS-FH-I3	Rank FC6		$I_F = 100\text{mA}$	140	150	155	lm
	Rank FC7			150	160		lm
	Rank FC8			160	170		lm
Reverse Current		I_R	$V_R = 15\text{V}$	---	10	---	μA
Viewing Angle		2 1/2		---	---	120	Deg
Color Rendering Index(CRI	$I_F = 100\text{mA}$	80	---	81.5	---
Thermal resistance		R_{THJ-S}		---	---	15	/W

 Table 1-2 Absolute Maximum Ratings at Ts=25°C

Parameter	Symbol	Rating	Units
Power Dissipation	P_D	1080	mW
Forward Current	I_F	120	mA
Peak Forward Current	I_{FP}	220	mA
Reverse Voltage	V_R	15	V
Electrostatic Discharge(HBM)	ESD	2000	V
Operating Temperature	T_{OPR}	-40 ~ +105	
Storage Temperature	T_{STG}	-40 ~ +105	
Junction Temperature	T_J	125	

Notes

1. 1/10 Duty cycle, 0.1ms pulse width. 0.1ms, 1/10.
2. The above forward voltage measurement allowance tolerance is $\pm 0.1V$. $\pm 0.1V$.
3. The above color coordinates measurement allowance tolerance is 0.005. 0.005.
4. The above luminous intensity measurement allowance tolerance $\pm 10\%$. $\pm 10\%$.
5. Care is to be taken that power dissipation does not exceed the absolute maximum rating of the product.
6. All measurements were made under the standardized environment of Refond.
7. When the LEDs are in operation the maximum current should be decided after measuring the package temperature. Junction temperature should not exceed the maximum rate. LED
8. ESD yield is over 90% at 2000V ESD (HBM). ESD protection during products handling is needed. 90% LED
ESD2000V

1.6 Bin Range Of Forward Voltage and Luminous Flux (IF=100mA)

BIN (IF=100mA)

Table 1-3

V _F V	Y0	Z0	
	8.6-9.0	9.0-9.4	
φ Im RF-W57HP32DS-FH-I3 RF-W6HP32DS-FH-I3	FC6	FC7	FC8
	140-150	150-160	160-170

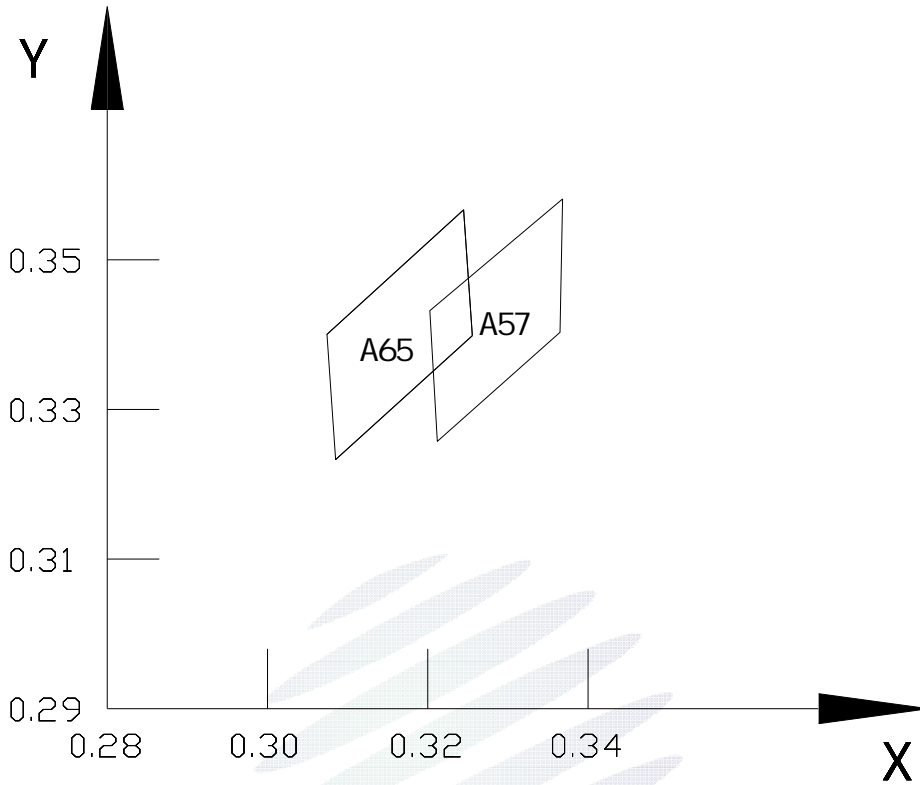

Fig 1-6 The C.I.E Chromaticity Diagram CIE

Table 1-4

6-step								
BIN CODE	X1	Y1	X2	Y2	X3	Y3	X4	Y4
A57	0.3203	0.3432	0.3368	0.3581	0.3365	0.3403	0.3212	0.3257
A65	0.3245	0.3567	0.3074	0.3400	0.3085	0.3233	0.3256	0.3399

1.7 Typical optical characteristics curves

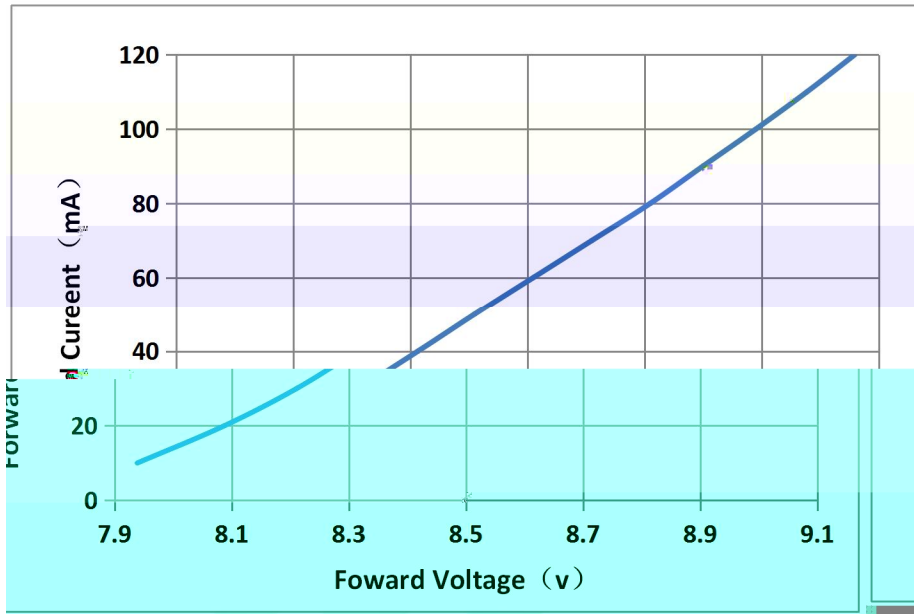

Fig 1-7 Forward Voltage Vs. Forward Current

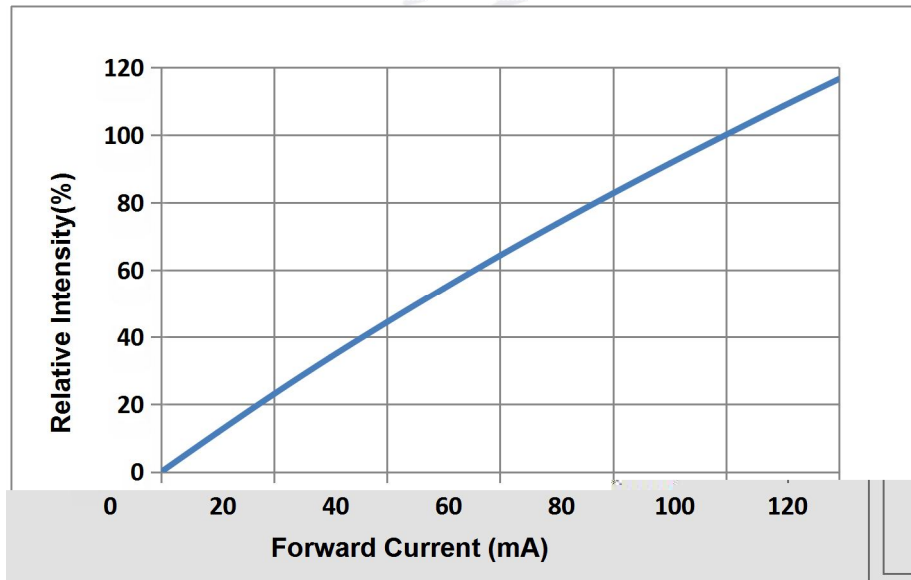

Fig 1-8 Forward Current Vs. Relative Intensity

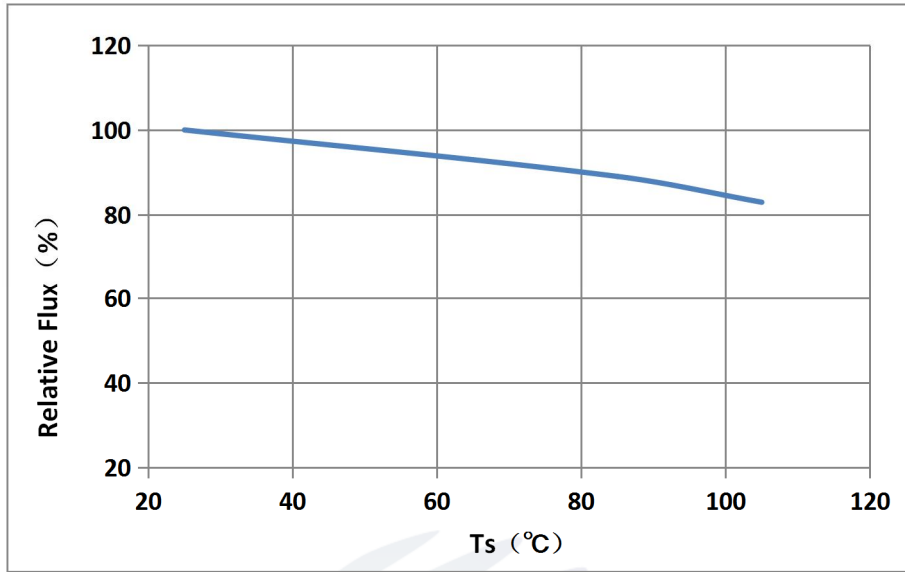

Fig 1-9 Solder Temperature Vs Relative Intensity

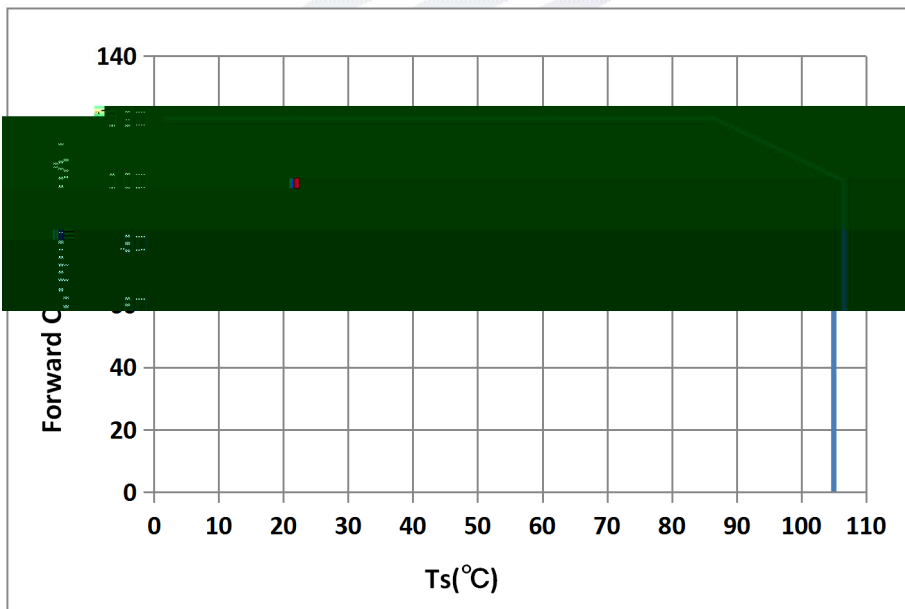

Fig 1-10 Solder Temperature Vs Forward Current

Tj 125

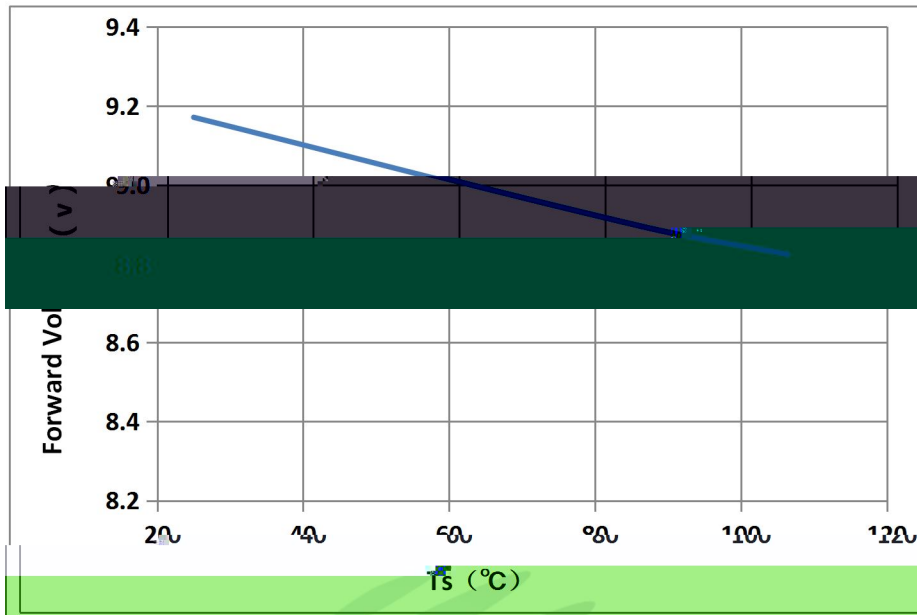

Fig 1-11 Forward Voltage Vs Solder Temperature

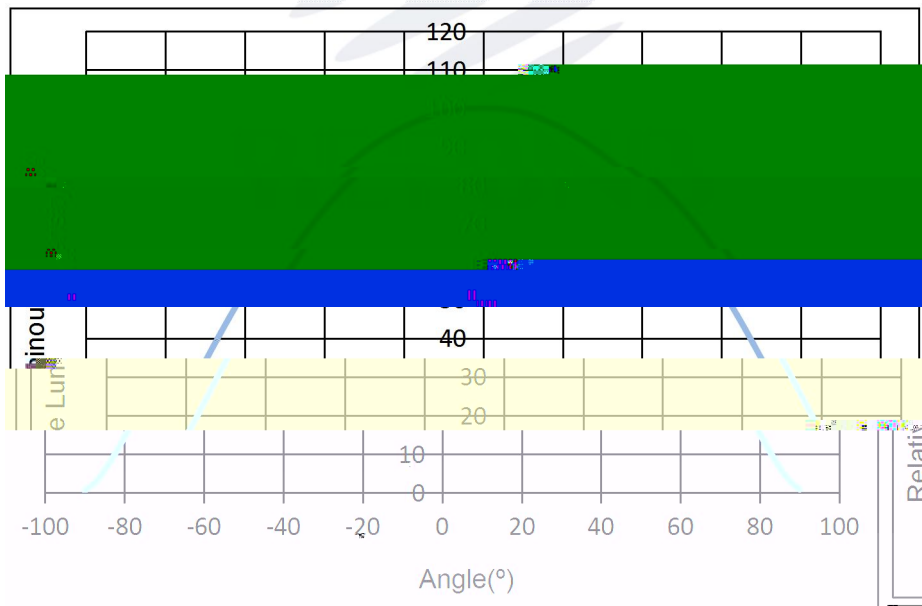

Fig 1-12 Radiation diagram

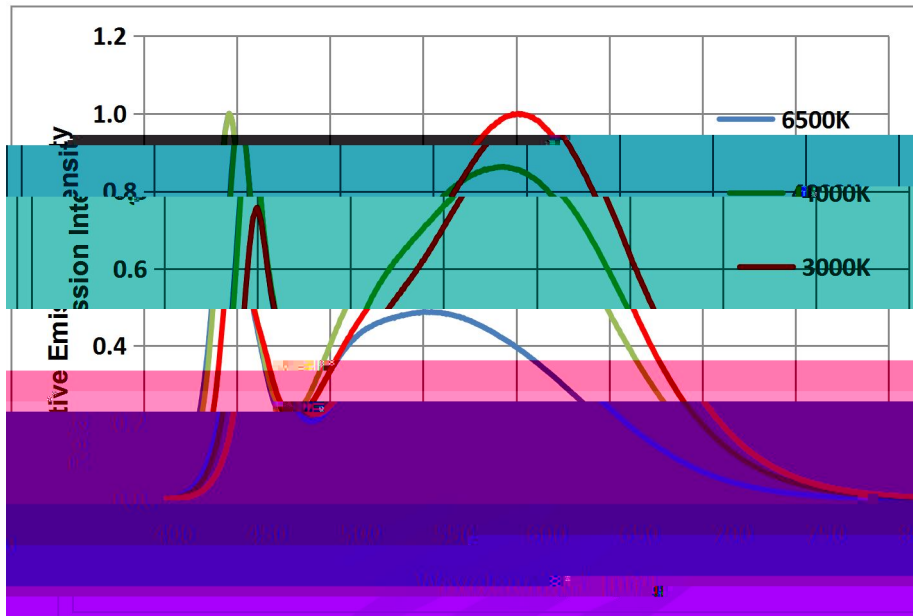

Fig 1-13 Spectrum Distribution

REFOND

2. Packaging

2.1 Packaging Specification

Package: 12000pcs/reel. 12000pcs

2.1.1 Carrier Tape Dimension

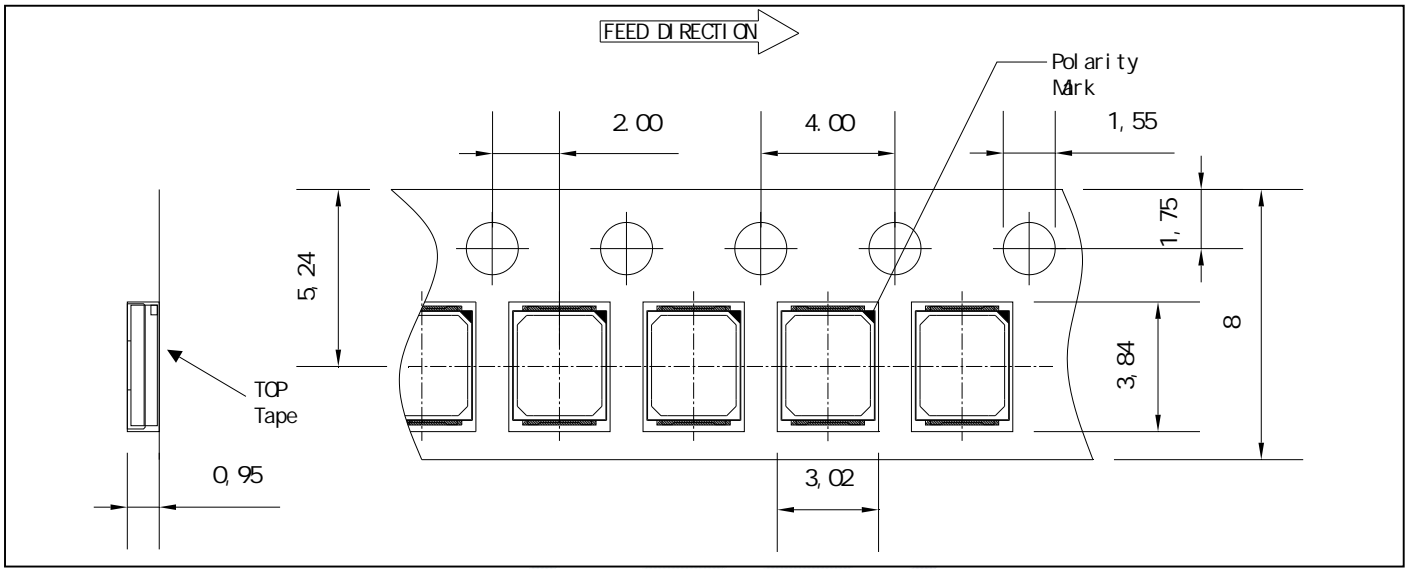

Fig.2-1 Carrier Tape Dimension

2.1.2 Reel Dimension

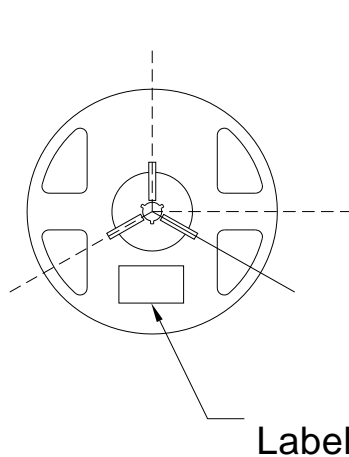

Fig.2-2 Title

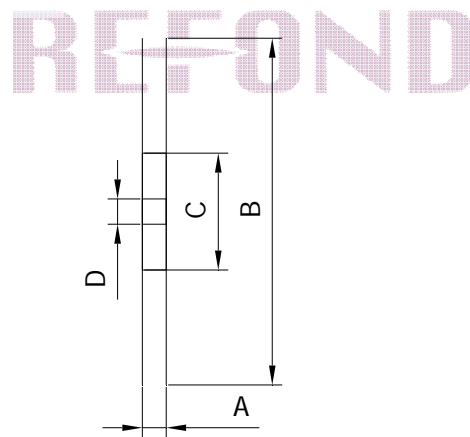

Table 2-1 Title

A	12.2±0.3mm
B	290±2mm
C	79.6±0.2mm
D	14.2±0.2mm

Notes

The tolerances unless mentioned ± 0.1 mm. Unit : mm ± 0.1

2.4 Reliability Test Items And Conditions

Table 2-3 Title

TestItems	Ref.Standard	Test Condition	Time	Quantity	Ac/Re /
Reflow	JESD22-B106	Temp:260 max T=10 sec	2times	10pcs	0/1
Thermal Shock	JEITAED-4701 300307	-40 15min 10s 100 15min	200cycles	10pcs	0/1
High Temperature Storage	JEITAED-4701 200 201	Temp:100	1000hrs	10pcs	0/1
Low Temperature Storage	JEITA ED-4701 200 202	Temp:-40	1000hrs	10pcs	0/1
Life Test	JESD22-A108	Ta=25 If=100mA	1000hrs	10pcs	0/1
High Temperature High Humidity Life Test	JESD22-A101	60 / 90%RH If=100mA	1000hrs	10pcs	0/1
Temperature Humidity Storage	JEITA ED-4701 100 103	TA=85 RH=85%	1000hrs	10pcs	0/1
Sulfur test	/	80 4H 0.6	4hrs	10pcs	0/1

2.5 Criteria For Judging Damage

Table 2-4 Title

Items	Symbol	Test Condition	Criteria For Judgement	
			Min.	Max.
Forward Voltage	V_F	$I_F=100mA$	-	(U.S.L*)x1.1
Reverse Current				

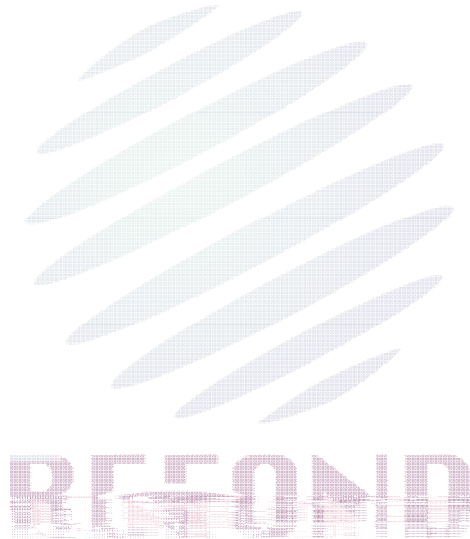

3. SMT Reflow Soldering Instructions SMT

3.1 SMT Reflow Soldering Instructions SMT

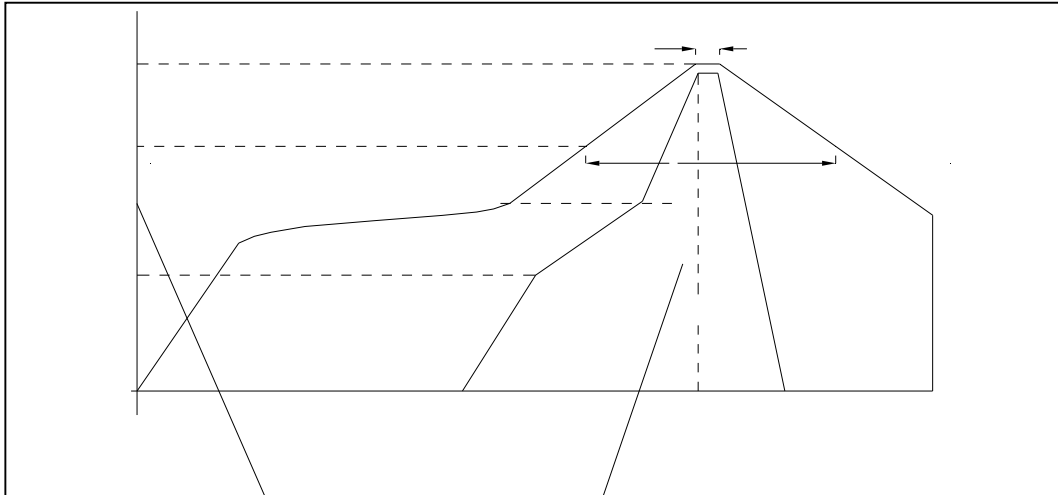

Fig.3-1Title

Table 3-1Title

Average temperature rise speed	T _{smax}	T _P	3 °C/	Max 3 °C/
Preheating: minimum temperature	(T _{smin})		150 °C	
Preheating: Max temperature	(T _{smax})		200 °C	
Preheating: Time	T _{smin}	T _{smax}	60 - 120	60s-120s
Time limited to maintain high temperature: the temperature		(T _L)	217 °C	
Time limited to maintain high temperature: The Time		(t _L)	60	Max 60s
Peak /Classification of temperature:	/	(T _P)	260 °C	
Time limit classification of peak temperature time		t _p	10	Max 10s
Hold time within 5 °C with the actual peak temperature (TP)		(T _P)	30	Max 30s
5 °C				
Cooling speed			6 °C/	Max 6 °C/
Needed time from 25 °C to T _p	25 °C		8	Max 8

Notes

(1)Reflow soldering should not be done more than two times. In the case of more than 24 hours passed soldering after first, LEDs will be damaged. 24

LED

(2)When soldering , do not put stress on the LEDs during heating.

3.1.1 Soldering Iron

(1) When hand soldering, keep the temperature of iron below less 300 less than 3 seconds
300 3

(2) The hand solder should be done only one time.

3.1.2 Repairing

Repair should not be done after the LEDs have been soldered. When repairing is unavoidable, a double-head soldering iron should be used (as below figure). It should be confirmed in advance whether the characteristics of LEDs will or will not be damaged by repairing.

LED

LED



3.1.3 Cautions

(1) The encapsulated material of the LEDs is silicone. Therefore the LEDs have a soft surface on the top of package. The pressure to the top surface will be influence to the reliability of the LEDs. Precautions should be taken to avoid the strong pressure on the encapsulated part. So when use the picking up nozzle, the pressure on the silicone resin should be proper. LED

LED

d

(3) Do not apply mechanical force or excess vibration during the cooling process to normal temperature after soldering. Do not rapidly cool device after soldering.

4. Handling Precautions

4.1 Handling Precautions

(1) LED operating environment and sulfur element composition cannot be over 100PPM in the LED mating usage material. This is provided for informational purposes only and is not a warranty or endorsement.

LED	LED	100PPM	S	d	OP
-----	-----	--------	---	---	----

(2) In order to prevent external material from getting into the inside of LED, which may cause the malfunction of LED, the single content of Bromine element is required to be less than 900PPM, the single content of Chlorine element is required to be less than 900PPM, the total content of Bromine element and Chlorine element in the external materials of the application products is required to be less than 1500PPM. This is provided for informational purposes only and is not a warranty or endorsement.



LED

(4) Handle the component along the side surface by using forceps or appropriate tools; do not directly touch or Handle the silicone lens surface, it may damage the Antenna property.

Fig 4-1 Title

(5) In designing a circuit, the current through each LED can not exceed the absolute maximum rating specified for each LED. In the mean while, resistors for protection should be applied, otherwise slight voltage shift will cause big current change, burn out may happen. The driving circuit must be designed to allow forward voltage only when it is ON or OFF. If the reverse voltage is applied, LED degradation can be generated, resulting in LED damage.

LED

S



\\#0k+U Ec\$!t 7^7c^S .Blu %Ž•\$7Å

package or resin. Ultrasonic cleaning is not recommended. Ultrasonic cleaning may cause damage to the LED.

LED

Table 4-1 Storage

Conditions		Temperature	Humidity	Time
Storage	Before Opening Aluminum Bag	30	75%	Within 1 Year From Date
	After Opening Aluminum Bag	30	60%	24hours 24
Baking		60±5	-	24hours 24

(8) If the moisture absorbent material silica gel has faded away or the LEDs have exceeded the storage time baking treatment should be performed after unpacking and based on the following condition way

Version History/

Date	Revisor	Version	Verifier	Remarks
2020-12-30		E/0		





www.refond.com

REFOND

Declare

This specification is written both in English and in Chinese and the latter is formal.